

ITD2778, ITD2790, ITD2878, ITD2890, ITD1751



SERIESTM
DOLLIES
AND AXLES

MANUAL

EDITION-6 VOLUME-1



**VISIT OUR WEBSITE!
IN THE DITCH.COM**



**PHONE: 1-208-587-7960
EMAIL: sales@intheditch.com**

MANUAL INFORMATION

INTRODUCTION

Everyone here at In The Ditch™ would like to thank you for your recent purchase of one of our products, and tell you congratulations! Our passion is to provide our customers with the best products and parts money can buy, as well as serve the towing industry and our local community here in Mountain Home, Idaho! Without support from valued customers such as yourselves, our business, as well as the people who work for it, wouldn't survive. We hope you find our products useful, and get the most out of every experience with them. Thank you!



ATTENTION

This manual should be read carefully. It contains important information that needs to be fully understood and followed in order to ensure that the *In The Ditch* Products discussed in this manual are used properly so as to ensure the safety of all persons (e.g. operators, customers, bystanders).

CONTENTS

- **WARRANTY INFORMATION** ————— **4**

- **PARTS & ACCESSORIES** ————— **6**
 - X-Series™ XL-SD Dolly Replacement Parts ————— **6**
 - X-Series™ XL-XD Dolly Replacement Parts ————— **8**
 - X-Series™ SLX-SD Dolly Replacement Parts ————— **10**
 - X-Series™ SLX-XD Dolly Replacement Parts ————— **12**
 - XL OR SLX ————— **14**
 - XL Axle & Break-Over Bar Replacement Parts ————— **15**
 - How to Tell the Difference Between Axles ————— **16**
 - Don't Mix and Match Between Axles ————— **17**

- **SAFETY INFORMATION** ————— **18**
 - Safety & Precautions ————— **18**
 - Load Ratings ————— **18**

- **DOLLY MAINTENANCE** ————— **19**
 - Visual Inspection ————— **19**
 - Maintenance (Each Use) ————— **19**
 - Maintenance (3 Months) ————— **19**
 - Aluminum Wheel Care ————— **19**
 - Tire Inspection ————— **19**
 - Grease Points ————— **20**
 - Speed® Lube Through Spindle Lubrication System ————— **20**
 - Installation of Replacement Spindle Assemblies ————— **21**
 - Spindle Assembly Removal and Install: ————— **22**

- **DOLLY OPERATIONS** ————— **23**
 - Loading: ————— **23**
 - Transporting ————— **28**
 - Unloading ————— **28**
 - Tips & Tricks ————— **30**

WARRANTY INFORMATION

ITD0688R3

Limited Warranty

In The Ditch Towing Products (also referred to herein as ITD) warrants to the original purchaser that new ITD manufactured goods will be free from defects in material and workmanship for a period of twelve (12) months from the date placed in service. The purchaser must promptly notify ITD in writing of any failure in material or workmanship. In no event shall ITD accept such notification later than twelve (12) months from the date placed in service.

ITD's obligation under this warranty, statutory or otherwise, is limited to the repair or replacement at the ITD factory, or at a point designated by ITD, of such part or parts as shall appear upon inspection by ITD to be defective in material or workmanship. This warranty is not transferable. This warranty does not obligate ITD to bear the cost of labor or transportation charges in connection with the repair or replacement of any part(s) found to be defective, nor shall it apply to a product upon which repairs or alterations have been made unless such repairs or alterations were authorized by ITD.

Except as expressly set forth in this warranty, ITD makes no other warranty, express or implied, and hereby disclaims all other warranties including, but not limited to, the implied warranties of merchantability and fitness for a particular purpose. ITD shall in no event be liable for any claims for downtime, loss of profits or goodwill, or any claims for other special, incidental, indirect, or consequential damages concerning or relating to any product or parts, whether based on negligence, strict liability, breach of contract, breach of warranty, misrepresentation, or any other legal theory, regardless of whether the loss resulted from any general or particular requirement which ITD knew or had reason to know about at the time of sale.

ITD makes no warranty, express or implied, as to the finished products manufactured or supplied by another manufacturer and supplied by ITD to purchaser, including, but not limited to, any vehicle to which an ITD product may be affixed or any accessories, and ITD expressly disclaims any implied warranties of merchantability and fitness for a particular purpose as to such equipment or products. This language shall in no way affect or diminish the rights of the purchaser to rely on such warranties as are extended by such manufacturers or suppliers. ITD shall, to the extent permitted under applicable law, pass on to the purchaser such manufacturer's or seller's warranty.

The customer must obtain and present a written authorization number from ITD prior to any work beginning, and the customer agrees to bear all costs. Please note: Merchandise covered by a manufacturer's warranty must be sent directly to the manufacturer for replacement or repair. ITD, whose policy is one of continuous improvement, reserves the right to improve its products through changes in design or materials as it may deem desirable without being obligated to incorporate such changes in any products previously sold.

This warranty is not intended to cover and shall not apply or include the following items, which are set forth by way of example only: normal deterioration of trim, paint, lettering, appearance of items due to wear or exposure to weather, road conditions, road treatments, etc.; any damage or defect due to accident, misuse, abuse, operation exceeding rated loads, improper or unauthorized repairs, failure to provide reasonable and necessary maintenance, or uses in respect of which the equipment was not designed or intended; alterations or modifications that affect performance, operations, or reliability.

It is expressly understood that ITD makes no implied or express warranty that ITD manufactured goods shall be fit for the purpose of lifting or moving people or for any other improper use. Field modification of this unit without the advice and written consent of the ITD Engineering Department will void all warranties and any guarantees pertaining to both purchased components used in the manufacture of this unit, as well as structurally fabricated parts supplied by ITD. Use of other than factory or factory authorized parts will render the warranty void.

Notice to Owner or User

It is very important that you properly fill out your product registration form at registration.intheditch.com to register your equipment. By submitting the information within 15 days of your purchase, your warranty will be validated, ensuring that your equipment will be protected subject to the terms and conditions set out herein. In the event we need to contact you concerning your registered equipment, Product Updates, Service Bulletins, or Product Recalls, the information you have provided on the product registration form will ensure your immediate notification. Do your part and let us help you by filling out your product registration form.

Installation Guidelines

Due to variances in manufacturers' wrecker bodies, truck bodies and mounting surfaces, ITD cannot provide explicit mounting requirements for every mounting option. These instructions are to serve only as a guideline. Final installation requirements are left to the discretion of a qualified installer.

Assumption of Risk

Towing and recovery (collectively "Towing") is by nature an inherently dangerous activity. As a consequence, towing operators assume the risk of serious injury or death. ITD products are only intended to be used solely by towing operators who have the requisite training and experience who not only understand the proper use of the product/s but also fully understand all risks associated with towing.

If you do not have the requisite experience and training as a towing operator DO NOT USE these products.

WARRANTY INFORMATION

ITD0688R3

Inspection

- ITD requires that each operator of a truck or transport vehicle perform a detailed circle check before and after each use of the truck or transport vehicle. This inspection must include the power unit, the towing unit, and all items installed on the unit.
- Do not take chances with your life or other people's lives. Make sure all items are secured and in safe working order.
- Always inspect products for any signs of paint cracking, metal fatigue or premature wear.
- Maintain a visual inspection along with grabbing the products and wiggling or pulling on it to make sure there is no way anything can become dislodged from its mount.
- Remove from service immediately if repairs are needed. Do not take chances.

Paint, Powder Coated and Polished Finishes:

The ITD warranty does not cover coatings or finishes, of powder coated products, galvanized products, zinc plated products, bare aluminum products, polished or non-polished stainless steel products or finishes. This includes, but is not limited to, scratches, peeling, chipping, hazing, dulling of finish or surface.

Modifications to ITD Products

- DO NOT modify or tamper with any ITD Product. Doing so will void any applicable warranty and may result in serious injury or death.
- Warranties will be voided if any ITD Product is modified or tampered with.

Securement

- The driver/operator must verify that all hardware is secure and tight. This includes, but is not limited to, mounting hardware and retaining systems.
- It is the driver /operator's responsibility to ensure that nothing can come loose from any part of the truck or transport vehicle or the vehicle being towed. It is the operator's responsibility to make sure that all items are in good working order and are properly secured.
- Only a qualified installer should mount ITD equipment. It is the installer's responsibility to ensure mounts are secure.
- It is the operator's responsibility to ensure his or her load is secured properly to the mounts.
- ITD recommends taking this approach to load/product securement:
 1. Imagine if you took your truck and turned it upside down. Nothing should fall out of or off of the truck.
 2. Now imagine if you stood the truck on the end where the front bumper was facing straight up into the sky. Nothing should fall out of or off the truck.
 3. Now imagine the rear bumper was facing the sky. Nothing should fall out of or off of the truck.

Mix and Matching of different Manufacturer's Products

- Only use In The Ditch brand mounts with In The Ditch Products.
- Only use In The Ditch brand replacement parts for In The Ditch brand products.
- Don't Mix and Match Axles
- Failure to do so may result in voiding any applicable warranty and serious bodily injury or death.



PARTS & ACCESSORIES

PARTS & ACCESSORIES



ITD2778 eXtended Life™ Standard Duty X-Series™ Dolly Set
(4.80 - 8" Tire, ITD Endurance™ Powder Coat Black, Aluminum Wheels)

ITD2778-P eXtended Life™ Standard Duty X-Series™ Dolly Set
(4.80 - 8" Tire, Zinc Plated, Aluminum Wheels)

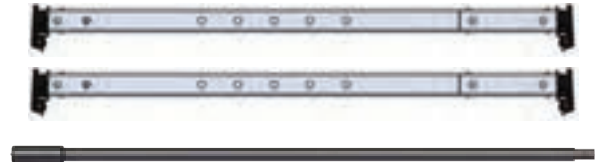

MIXING & MATCHING PRODUCTS

- Only use In The Ditch brand Mounts with In The Ditch brand products.
- Only use In The Ditch brand replacement parts for In The Ditch brand products.
- Don't Mix and Match Axles

ID	PART #	DESCRIPTION
1	ITD1778	XL-SD-X-Series™ Dolly (ITD) Endurance™ Powder Coat
-	ITD1778-P	XL-SD-X-Series™ Dolly (ITD Endurance™ Zinc Plated)
2	ITD1782	XL-SD-X-Series™ Dolly Frame only (No Hubs or Tires)
3	ITD7097	Chrome Acorn Lug Nut
4	ITD7094	4-Lug Aluminum Wheel
5	ITD7009	4.80 X 8 Load Range C Tire
6	ITD7098	4.80 X 8 4-Lug Aluminum Wheel & Tire Combo Mounted
7	ITD7013	2" Dust Cap
8	ITD7121	1" Nut Retainer
9	ITD7120	1" Jam Nut
10	ITD7119	1" D Washer
11	ITD7393	Sealed Hub Assembly
12	ITD7370-L	XL-SD-Replacement Bolt-On Spindle-Left (Includes ITD7377 x1, ITD7396 x2, 1/2" SS Washer x1, & 1/2" Thin Nylock Nut x1)
13	ITD7370-R	XL-SD-Replacement Bolt-On Spindle-Right (Includes ITD7377 x1, ITD7396 x2, 1/2" SS Washer x1, & 1/2" Thin Nylock Nut x1)
14	ITD7394	Dolly Pin Kit (Includes ITD7377 x1, ITD7396x2, 1/2" SS Washer x1, & 1/2" Thin Nylock Nut x1)
15	ITD7396	3/4" Bushing
16	ITD6562	Aluminum Dolly Handle (Includes Hardware)
17	ITD7166	Cam Lock Rebuild Kit(Includes ITD7167, ITD7002, ITD7301, ITD7043, & Threadlocker)
18	ITD1753	XL-SD-X-Series™ Dolly Replacement Decal Kit

Failure to follow the safety guidelines listed may result in voiding any applicable warranty, serious bodily injury, or death.

It is very important that you properly fill out your product registration form at registration.intheditch.com to register your equipment. By submitting the information within 15 days of your purchase, your warranty will be validated, ensuring that your equipment will be protected subject to the terms and conditions set out herein. In the event we need to contact you concerning your registered equipment, Product Updates, Service Bulletins, or Product Recalls, the information you have provided on the product registration form will ensure your immediate notification. Do your part and let us help you by filling out your product registration form.

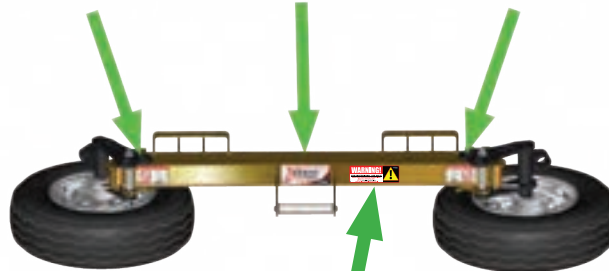
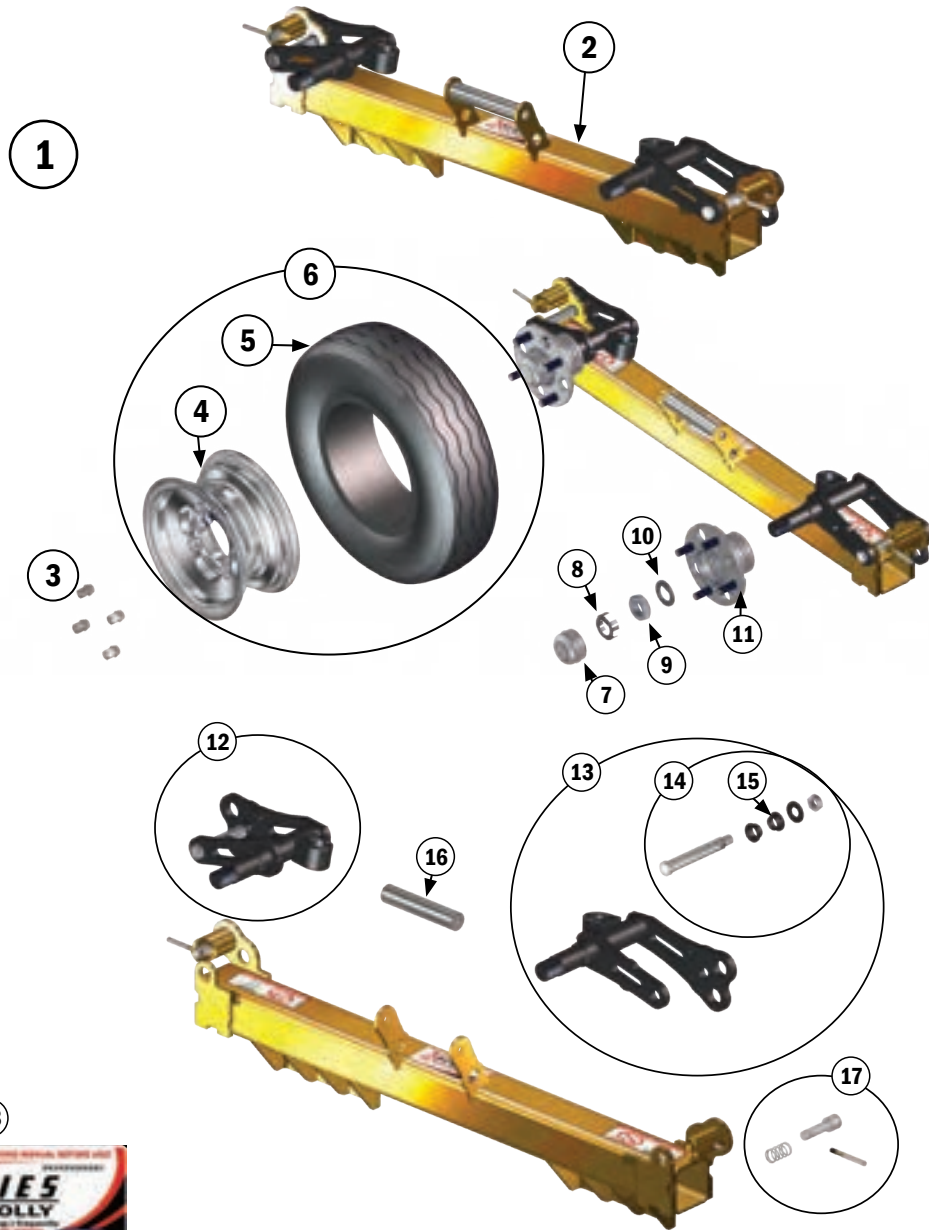

Replace any product decal that has become illegible. They are provided for your product and safety information.

⚠️ Failure to follow the safety guidelines listed may result in voiding any applicable warranty, serious bodily injury, or death.

⚠️ It is very important that you properly fill out your product registration form at registration.intheditch.com to register your equipment. By submitting the information within 15 days of your purchase, your warranty will be validated, ensuring that your equipment will be protected subject to the terms and conditions set out herein. In the event we need to contact you concerning your registered equipment, Product Updates, Service Bulletins, or Product Recalls, the information you have provided on the product registration form will ensure your immediate notification. Do your part and let us help you by filling out your product registration form.



ITD2790 eXtended Life™ eXtreme Duty™ X-Series™ Dolly Set
(5.70 - 8" Tire, ITD Endurance™ Powder Coat Black, Aluminum Wheels)

ITD2790-P eXtended Life™ eXtreme Duty™ X-Series™ Dolly Set
(5.70 - 8" Tire, Zinc Plated, Aluminum Wheels)



MIXING & MATCHING PRODUCTS

- Only use In The Ditch brand Mounts with In The Ditch brand products.
- Only use In The Ditch brand replacement parts for In The Ditch brand products.
- Don't Mix and Match Axles

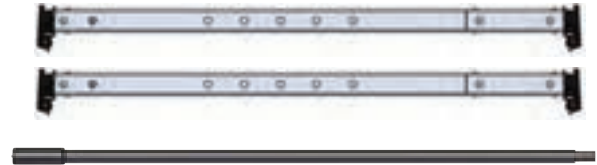

ID	PART #	DESCRIPTION
1	ITD1790	XL-XD-X-Series™ Dolly (ITD) Endurance™ Powder Coat
-	ITD1790-P	XL-XD-X-Series™ Dolly (ITD) Endurance™ Zinc Plated
2	ITD1792	XL-XD-X-Series™ Dolly Frame only (No Hubs or Tires)
3	ITD7097	Chrome Acorn Lug Nut
4	ITD7094	4-Lug Aluminum Wheel
5	ITD7093	5.70 X 8 Load Range D Tire
6	ITD7096	5.70 X 8 4-Lug Aluminum Wheel & Tire Combo Mounted
7	ITD7013	2" Dust Cap
8	ITD7121	1" Nut Retainer
9	ITD7120	1" Jam Nut
10	ITD7119	1" D Washer
11	ITD7393	Sealed Hub Assembly
12	ITD7909-L	XL-XD-Replacement Bolt-On Spindle-Left (Includes ITD7377 x1, ITD7396 x2, 1/2" SS Washer x1, & 1/2" Thin Nylock Nut x1)
13	ITD7909-R	XL-XD-Replacement Bolt-On Spindle-Right (Includes ITD7377 x1, ITD7396 x2, 1/2" SS Washer x1, & 1/2" Thin Nylock Nut x1)
14	ITD7394	Dolly Pin Kit (Includes ITD7377 x1, ITD7396 x2, 1/2" SS Washer x1, & 1/2" Thin Nylock Nut x1)
15	ITD7396	3/4" Bushing
16	ITD6562	Aluminum Dolly Handle (Includes Hardware)
17	ITD7166	Cam Lock Rebuild Kit(Includes ITD7167, ITD7002, ITD7301, ITD7043, & Threadlocker)
18	ITD1754	XL-XD-X-Series™ Dolly Replacement Decal Kit

Failure to follow the safety guidelines listed may result in voiding any applicable warranty, serious bodily injury, or death.

It is very important that you properly fill out your product registration form at registration.intheditch.com to register your equipment. By submitting the information within 15 days of your purchase, your warranty will be validated, ensuring that your equipment will be protected subject to the terms and conditions set out herein. In the event we need to contact you concerning your registered equipment, Product Updates, Service Bulletins, or Product Recalls, the information you have provided on the product registration form will ensure your immediate notification. Do your part and let us help you by filling out your product registration form.

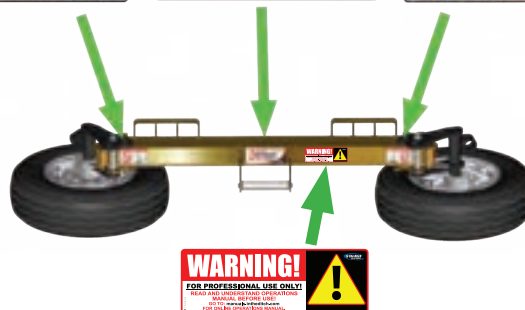
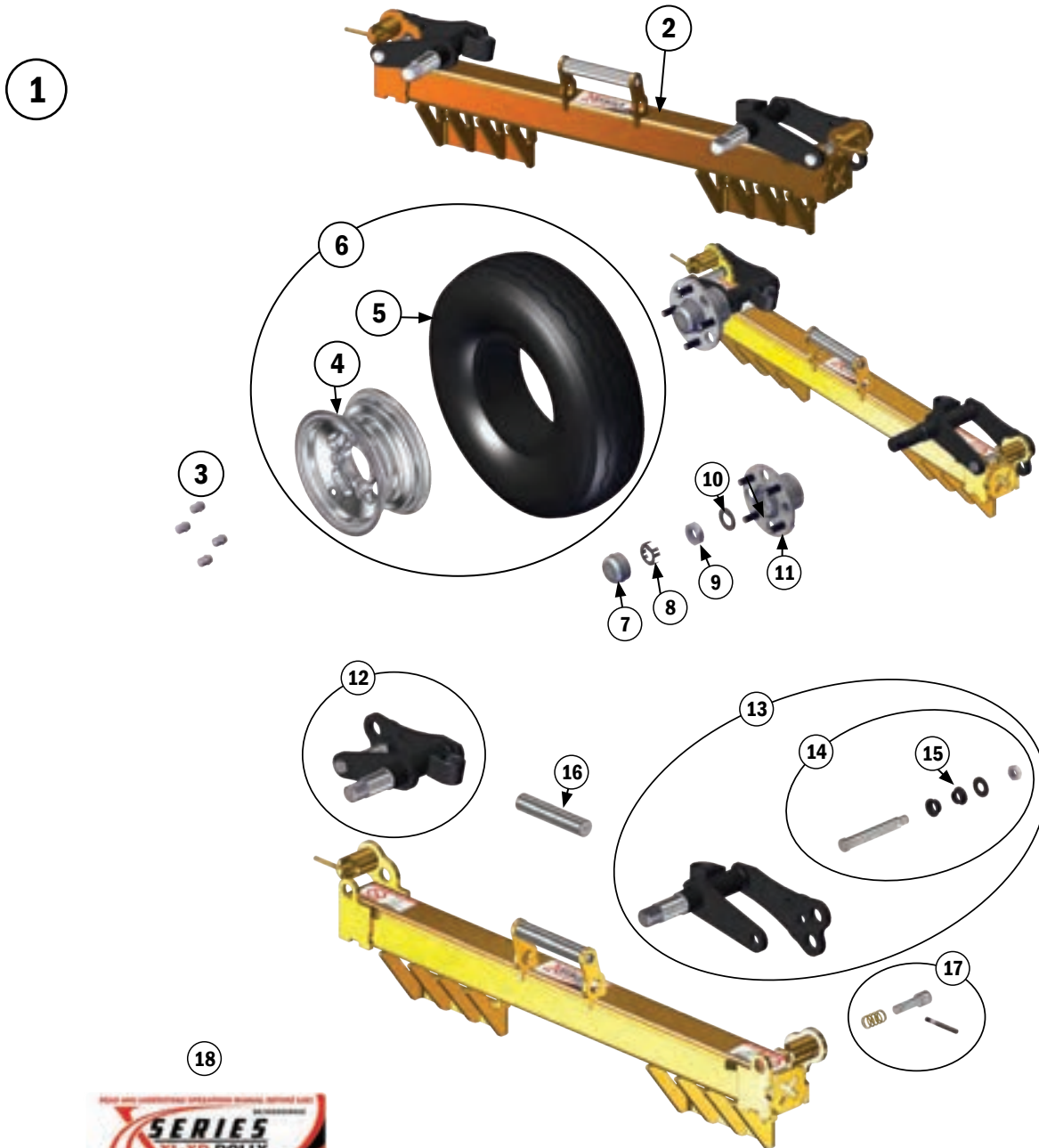

Replace any product decal that has become illegible. They are provided for your product and safety information.

⚠️ Failure to follow the safety guidelines listed may result in voiding any applicable warranty, serious bodily injury, or death.

⚠️ It is very important that you properly fill out your product registration form at registration.intheditch.com to register your equipment. By submitting the information within 15 days of your purchase, your warranty will be validated, ensuring that your equipment will be protected subject to the terms and conditions set out herein. In the event we need to contact you concerning your registered equipment, Product Updates, Service Bulletins, or Product Recalls, the information you have provided on the product registration form will ensure your immediate notification. Do your part and let us help you by filling out your product registration form.



ITD2878 Speed® Lube X-Series™ Standard Duty Dolly Set
(4.80 - 8" Tire, ITD Endurance™ Powder Coat Black, Aluminum Wheels)

ITD2878-P Speed® Lube X-Series™ Standard Duty Dolly Set
(4.80 - 8" Tire, Zinc Plated, Aluminum Wheels)

MIXING & MATCHING PRODUCTS

- Only use In The Ditch brand Mounts with In The Ditch brand products.
- Only use In The Ditch brand replacement parts for In The Ditch brand products.
- Don't Mix and Match Axles

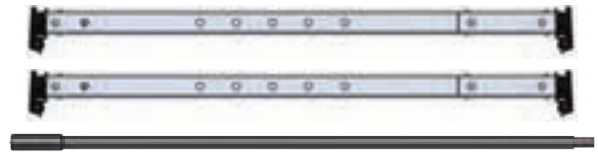

ID	PART #	DESCRIPTION
1	ITD1878	SLX-SD-X-Series™ Dolly (ITD) Endurance™ Powder Coat
-	ITD1878-P	SLX-SD-X-Series™ Dolly (ITD Endurance™ Zinc Plated)
2	ITD1882	SLX-SD-X-Series™ Dolly Frame only (No Hubs or Tires)
3	ITD7097	Chrome Acorn Lug Nut
4	ITD7094	4-Lug Aluminum Wheel
5	ITD7009	4.80 X 8 Load Range C Tire
6	ITD7098	4.80 X 8 4-Lug Aluminum Wheel & Tire Combo Mounted
7	ITD7123	2" SLX Dust Cap Rubber Plug
8	ITD7122	2" SLX Dust Cap
9	ITD7121	1" Nut Retainer
10	ITD7120	1" Jam Nut
11	ITD7119	1" D Washer
12	ITD7118	Replacement Bearing & Race for Dollies
13	ITD7003	Hub Assembly with Bearings, Races, and Seal Installed
14	ITD7011	Grease Seal
15	ITD7906-L	SLX-SD-Replacement Bolt-On Spindle-Left (Includes ITD7377 x1, ITD7396 x2, 1/2" SS Washer x1, & 1/2" Thin Nylock Nut x1)
16	ITD7906-R	SLX-SD-Replacement Bolt-On Spindle-Right (Includes ITD7377 x1, ITD7396 x2, 1/2" SS Washer x1, & 1/2" Thin Nylock Nut x1)
17	ITD7394	Dolly Pin Kit (Includes ITD7377 x1, ITD7396 x2, 1/2" SS Washer x1, & 1/2" Thin Nylock Nut x1)
18	ITD7396	3/4" Bushing
19	ITD6562	Aluminum Dolly Handle (Includes Hardware)
20	ITD7166	Cam Lock Rebuild Kit(Includes ITD7167, ITD7002, ITD7301, ITD7043, & Threadlocker)
21	ITD1753	SLX-SD-X-Series™ Dolly Replacement Decal Kit

Failure to follow the safety guidelines listed may result in voiding any applicable warranty, serious bodily injury, or death.

It is very important that you properly fill out your product registration form at registration.intheditch.com to register your equipment. By submitting the information within 15 days of your purchase, your warranty will be validated, ensuring that your equipment will be protected subject to the terms and conditions set out herein. In the event we need to contact you concerning your registered equipment, Product Updates, Service Bulletins, or Product Recalls, the information you have provided on the product registration form will ensure your immediate notification. Do your part and let us help you by filling out your product registration form.

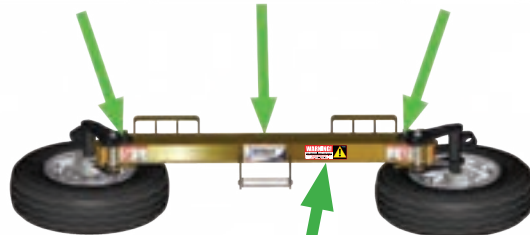
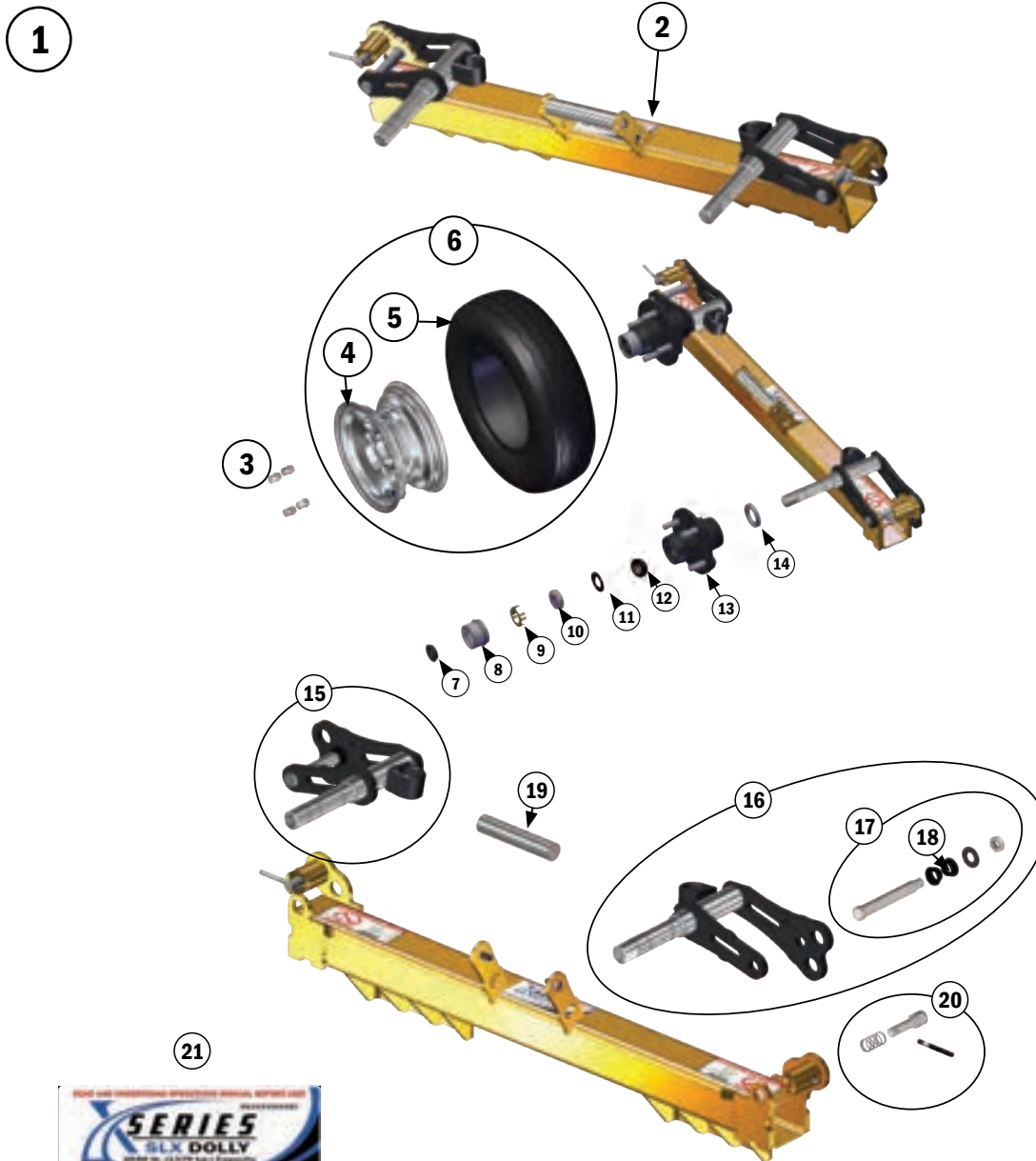

Replace any product decal that has become illegible. They are provided for your product and safety information.

⚠️ Failure to follow the safety guidelines listed may result in voiding any applicable warranty, serious bodily injury, or death.

⚠️ It is very important that you properly fill out your product registration form at registration.intheditch.com to register your equipment. By submitting the information within 15 days of your purchase, your warranty will be validated, ensuring that your equipment will be protected subject to the terms and conditions set out herein. In the event we need to contact you concerning your registered equipment, Product Updates, Service Bulletins, or Product Recalls, the information you have provided on the product registration form will ensure your immediate notification. Do your part and let us help you by filling out your product registration form.



ITD2890 Speed® Lube X-Series™ eXtreme Duty™ Dolly Set
(5.70 - 8" Tire, ITD Endurance™ Powder Coat Black, Aluminum Wheels)

ITD2890-P Speed® Lube X-Series™ eXtreme Duty™ Dolly Set
(5.70 - 8" Tire, Zinc Plated, Aluminum Wheels)

MIXING & MATCHING PRODUCTS

- Only use In The Ditch brand Mounts with In The Ditch brand products.
- Only use In The Ditch brand replacement parts for In The Ditch brand products.
- Don't Mix and Match Axles

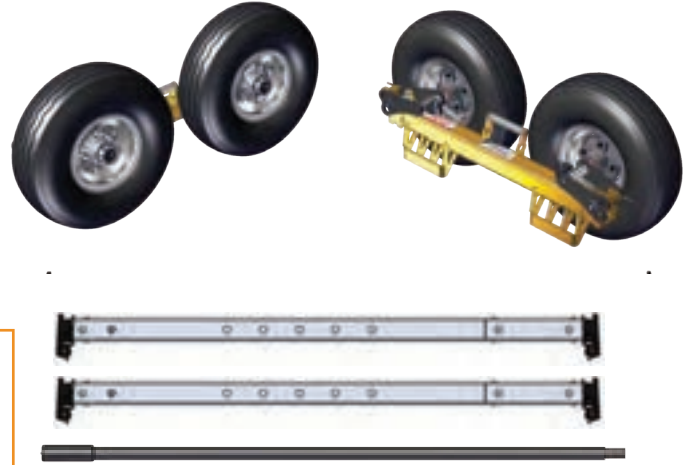

ID	PART #	DESCRIPTION
1	ITD1890	SLX-XD-X-Series™ Dolly (ITD) Endurance™ Powder Coat
-	ITD1890-P	SLX-XD-X-Series™ Dolly (ITD Endurance™ Zinc Plated)
2	ITD1892	SLX-XD-X-Series™ Dolly Frame only (No Hubs or Tires)
3	ITD7097	Chrome Acorn Lug Nut
4	ITD7094	4-Lug Aluminum Wheel
5	ITD7093	5.70 X 8 Load Range D Tire
6	ITD7096	5.70 X 8 4-Lug Aluminum Wheel & Tire Combo Mounted
7	ITD7123	2" SLX Dust Cap Rubber Plug
8	ITD7122	2" SLX Dust Cap
9	ITD7121	1" Nut Retainer
10	ITD7120	1" Jam Nut
11	ITD7119	1" D Washer
12	ITD7118	Replacement Bearing & Race for Dollies
13	ITD7003	Hub Assembly with Bearings, Races, and Seal Installed
14	ITD7011	Grease Seal
15	ITD7907-L	SLX-XD-Replacement Bolt On Spindle-Left (Includes ITD7377 x1, ITD7396 x2, 1/2" SS Washer x1, & 1/2" Thin Nylock Nut x1)
16	ITD7907-R	SLX-XD-Replacement Bolt On Spindle-Right (Includes ITD7377 x1, ITD7396 x2, 1/2" SS Washer x1, & 1/2" Thin Nylock Nut x1)
17	ITD7394	Dolly Pin Kit (Includes ITD7377 x1, ITD7396 x2, 1/2" SS Washer x1, & 1/2" Thin Nylock Nut x1)
18	ITD7396	3/4" Bushing
19	ITD6562	Aluminum Dolly Handle (Includes Hardware)
20	ITD7166	Cam Lock Rebuild Kit(Includes ITD7167, ITD7002, ITD7301, ITD7043, & Threadlocker)
21	ITD1753	SLX-XD-X-Series™ Dolly Replacement Decal Kit

Failure to follow the safety guidelines listed may result in voiding any applicable warranty, serious bodily injury, or death.

It is very important that you properly fill out your product registration form at registration.intheditch.com to register your equipment. By submitting the information within 15 days of your purchase, your warranty will be validated, ensuring that your equipment will be protected subject to the terms and conditions set out herein. In the event we need to contact you concerning your registered equipment, Product Updates, Service Bulletins, or Product Recalls, the information you have provided on the product registration form will ensure your immediate notification. Do your part and let us help you by filling out your product registration form.

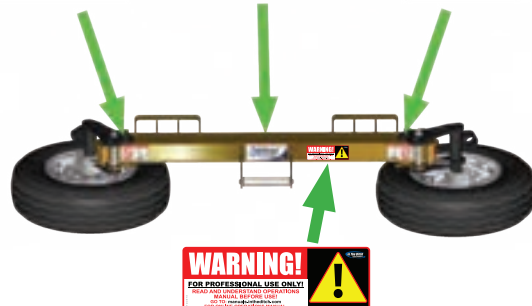
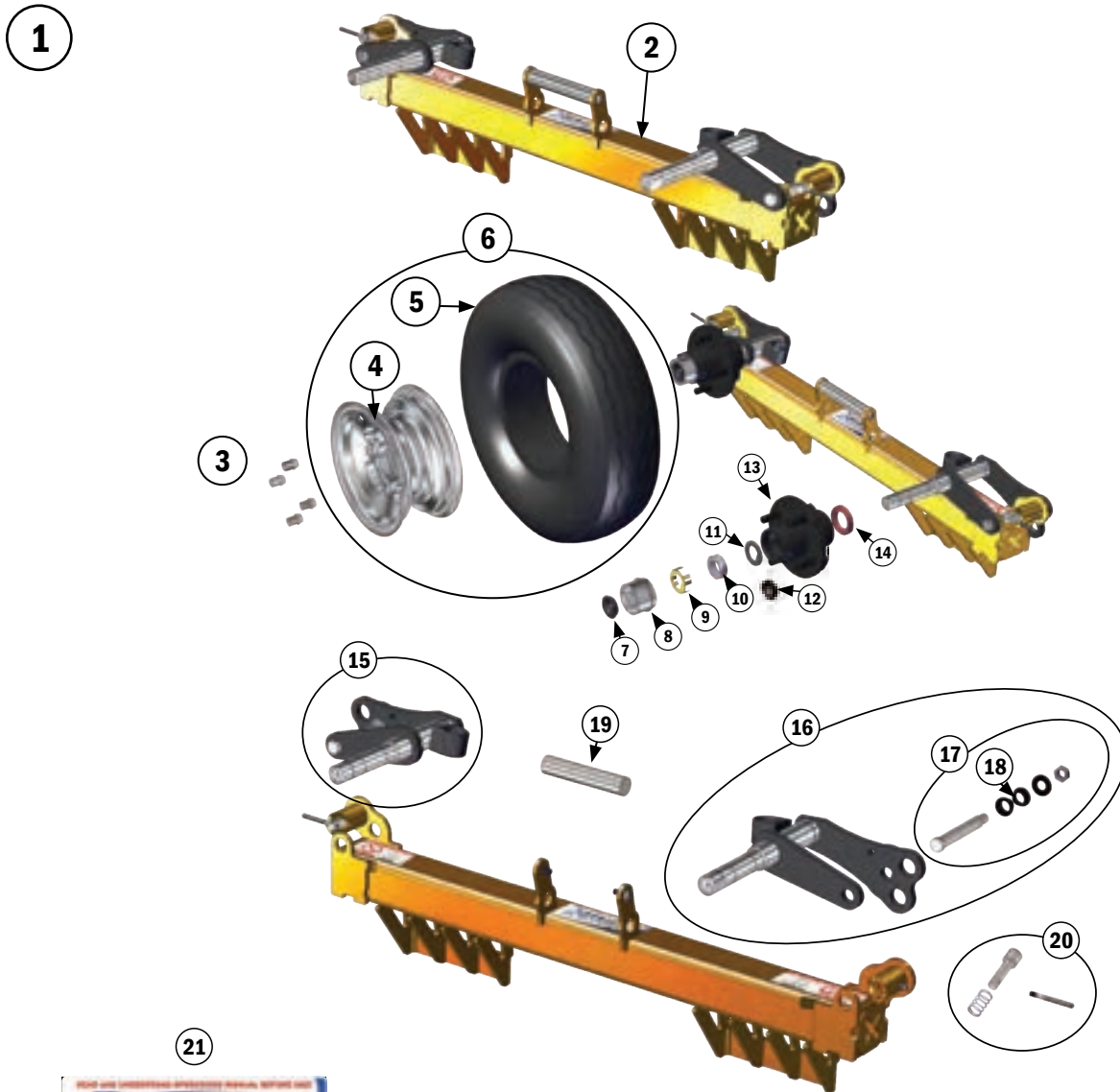

Replace any product decal that has become illegible. They are provided for your product and safety information.

Failure to follow the safety guidelines listed may result in voiding any applicable warranty, serious bodily injury, or death.

It is very important that you properly fill out your product registration form at registration.intheditch.com to register your equipment. By submitting the information within 15 days of your purchase, your warranty will be validated, ensuring that your equipment will be protected subject to the terms and conditions set out herein. In the event we need to contact you concerning your registered equipment, Product Updates, Service Bulletins, or Product Recalls, the information you have provided on the product registration form will ensure your immediate notification. Do your part and let us help you by filling out your product registration form.



OR



NEW AUTOMOTIVE SEALED HUB & BEARINGS
MAINTENANCE FREE / NEVER NEEDS GREASED!

CHOOSE YOUR HUB

When you choose an all new In The Ditch Speed® Dolly, you have choices. We still offer our awesome Speed® Lube Spindle on the new SLX line, but if you want even more out of your dollies, go for our XL Line! The XL brand has a new automotive grade sealed hub! It never needs greased, it's completely sealed, and it requires almost no maintenance to keep running thousands of miles.

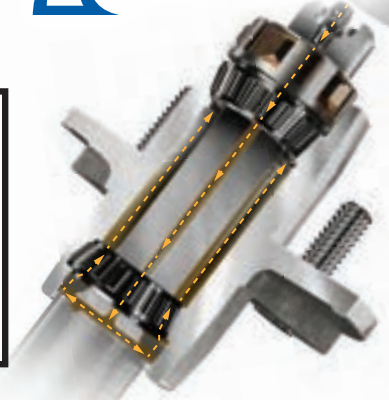

SPEED® LUBE
THROUGH SPINDLE LUBRICATION SYSTEM

CHOOSE YOUR CAPACITY

SD
STANDARD DUTY
3040lbs
CAPACITY

OR

XD™
EXTREME DUTY
4000lbs
CAPACITY



NEW BOLT ON, EASY TO REPLACE SPINDLE ASSEMBLY
WITH HIGH WEAR DURABLE BUSHINGS

Possibly the best part of buying a new SLX or XL Speed® Dolly, is the fact that you get tons of improvements no matter what you choose. From our awesome new Bolt-On Spindle Assembly, that comes in our new ITD Endurance™ Powdercoat finish, to our new Positive Camber XL Axles, which are some of the longest on the market, you know when you buy a new X-Series™ Dolly, you're getting The World's Most Advanced Dolly

No Compromises

▶ VIDEO ONLINE
www.intheditch.com



NEW FINISHES
ITD ENDURANCE™
POWDERCOAT BLACK
OR PLATED ZINC



SD vs XD Size Comparison

⚠ Failure to follow the safety guidelines listed may result in voiding any applicable warranty, serious bodily injury, or death.

⚠ It is very important that you properly fill out your product registration form at registration.intheditch.com to register your equipment. By submitting the information within 15 days of your purchase, your warranty will be validated, ensuring that your equipment will be protected subject to the terms and conditions set out herein. In the event we need to contact you concerning your registered equipment, Product Updates, Service Bulletins, or Product Recalls, the information you have provided on the product registration form will ensure your immediate notification. Do your part and let us help you by filling out your product registration form.

ITD1452 Break-Over Bar

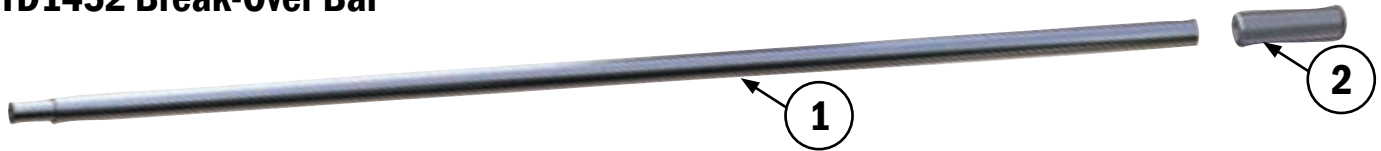

ID	PART #	DESCRIPTION
1	ITD1452	Break-Over Bar
2	ITD7019	Soft Grip Handle

ITD1751 Gen 4 X Series Axles - Confirm Axles Models on Page 16

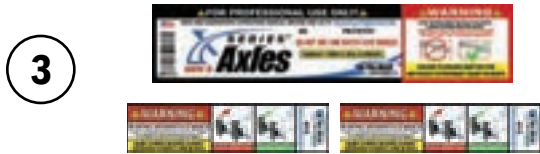

1	ITD1751	Gen 4 X Series Axle
2	ITD7008	Snap Button Pin
3	ITD1757	Replacement Gen 4 Axle Labels
4	ITD22092	T Plate for Tunnel Box

The "XL" in the ITD1751 X Gen 4 X Series Aluminum Telescoping Axle stands for eXtended Length.
The XL Aluminum Telescoping Axle extends up to 88.75".

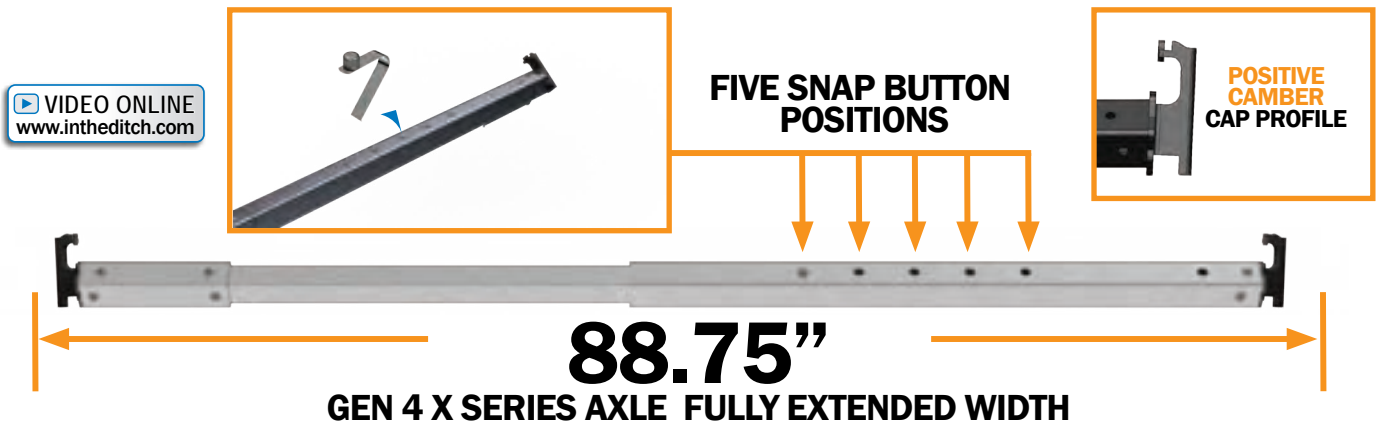

 Failure to follow the safety guidelines listed may result in voiding any applicable warranty, serious bodily injury, or death.

 It is very important that you properly fill out your product registration form at registration.intheditch.com to register your equipment. By submitting the information within 15 days of your purchase, your warranty will be validated, ensuring that your equipment will be protected subject to the terms and conditions set out herein. In the event we need to contact you concerning your registered equipment, Product Updates, Service Bulletins, or Product Recalls, the information you have provided on the product registration form will ensure your immediate notification. Do your part and let us help you by filling out your product registration form.

How to Tell the Difference Between Axles

There are drastic differences between our 4 generations of axles. To tell the differences between them, you must inspect some key features. Visualization of these features can be viewed in the images below. Our first generation, ITD1400 Standard Telescoping Axle, featured a non-cambered axle cap with 4 adjustment holes that extended to a max length of 81.5". Our second generation, ITD1401 Positive Camber Telescoping Axle, introduced a positive camber to the axle cap but maintained the same adjustability. Our 3rd generation, ITD1733 XL Aluminum Telescoping Axle, added a 5th adjustable position and extending the max adjustable length to 85". Our newest 4th generation, ITD1751 Gen 4 X-Series Axle, retains the positive camber and 5 adjustable holes, but now extends to a total of 88.75" and features a new axle cap profile.

Standard Telescoping Aluminum Axle (ITD1400)

GEN 1 ⊘ DISCONTINUED ⊘

Four position holes, extends to 81.5"

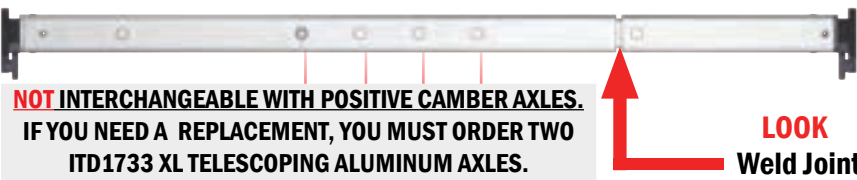

LOOK Weld Joint

NOT INTERCHANGEABLE WITH POSITIVE CAMBER AXLES. IF YOU NEED A REPLACEMENT, YOU MUST ORDER TWO ITD1733 XL TELESCOPING ALUMINUM AXLES.

ITD1400
STANDARD AXLE CAP PROFILE

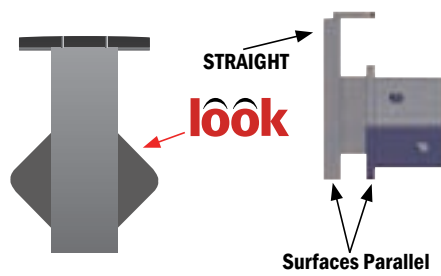

STRAIGHT

look

Surfaces Parallel

Positive Camber Telescoping Aluminum Axle (ITD1401)

GEN 2 ⊘ DISCONTINUED ⊘

Four position holes, extends to 81.5"

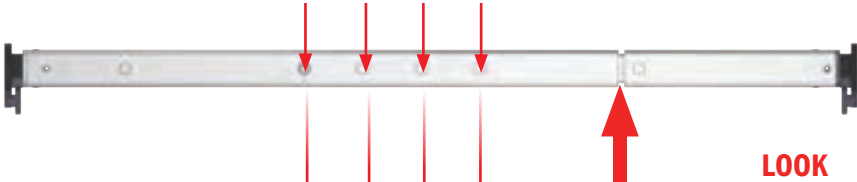

LOOK Weld Joint

ITD1401
POSITIVE CAMBER CAP PROFILE



ANGLED

look

3° Angle

STACKED PLATES

XL Positive Camber Telescoping Aluminum Axle (ITD1733)

GEN 3 ⊘ DISCONTINUED ⊘

Five position holes, extends to 85"



LOOK Weld Joint

5TH HOLE ADDED

ITD1733
XL POSITIVE CAMBER AXLE CAP PROFILE

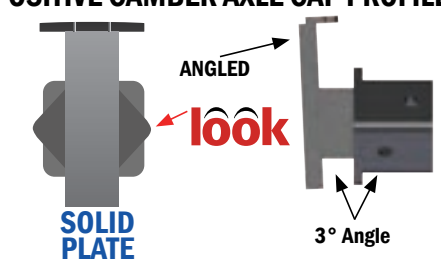

ANGLED

look

3° Angle

SOLID PLATE

Gen 4 X Series Axle Telescoping Aluminum Axle (ITD1751)

GEN 4 RELEASED MAY 2023

Five position holes, extends to 88.75"



LOOK New Riveted Joint Not Welded

WIDER HOLE SPACING

DO NOT MIX AND MATCH DIFFERENT GENERATION AXLES! (SEE PAGE 17)

ITD1751
GEN 4 X SERIES AXLE CAP PROFILE

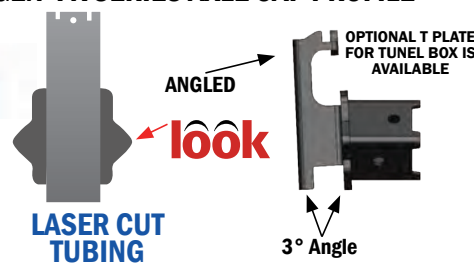

ANGLED

look



3° Angle

LASER CUT TUBING

OPTIONAL T PLATE FOR TUNEL BOX IS AVAILABLE

⚠ Failure to follow the safety guidelines listed may result in voiding any applicable warranty, serious bodily injury, or death.

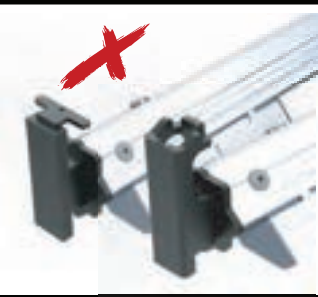
⚠ It is very important that you properly fill out your product registration form at registration.intheditch.com to register your equipment. By submitting the information within 15 days of your purchase, your warranty will be validated, ensuring that your equipment will be protected subject to the terms and conditions set out herein. In the event we need to contact you concerning your registered equipment, Product Updates, Service Bulletins, or Product Recalls, the information you have provided on the product registration form will ensure your immediate notification. Do your part and let us help you by filling out your product registration form.

<h1 style="margin: 0;">⚠️ WARNING ⚠️</h1>		
<p>DO NOT MIX AND MATCH AXLE MODELS! CHECK THE OPERATION MANUAL TO VERIFY AXLE MODEL. AXLE MODELS ARE NOT INTERCHANGEABLE.</p>	<p>DO NOT MIX AND MATCH AXLES</p>	<p>MATCH AXLES - GOOD TO USE</p>
<p>FAILURE TO COMPLY MAY RESULT IN INJURY, DESTRUCTION OF PROPERTY AND/ OR DEATH.</p>		

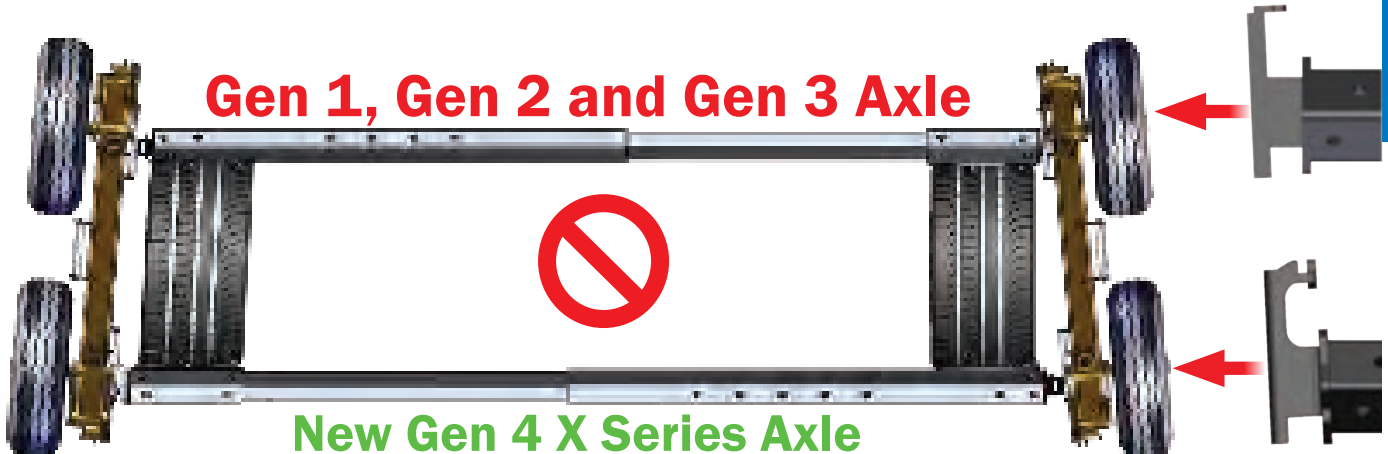

Don't Mix and Match Axles

“SEE PAGE 16”

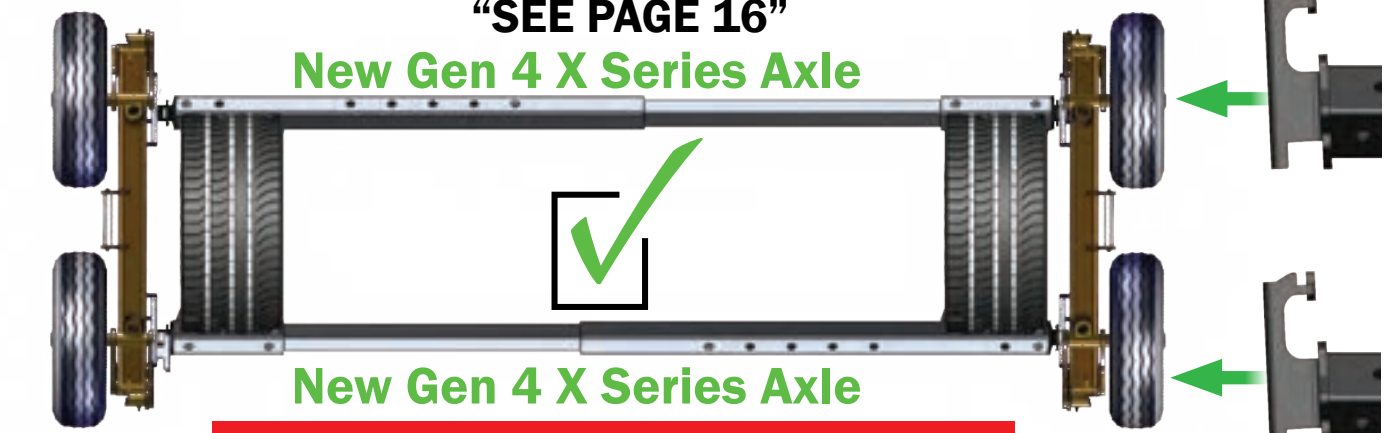

WARNING

Don't Mix and Match Axles; Failure to comply may result in:

- Damage to and/or failure of equipment
- Property damage, bodily injury, or death
- Premature tire wear

ITD1751
**GEN 4 X SERIES AXLE
CAP PROFILE**
OPTIONAL T PLATE
FOR TUNEL BOX IS
AVAILABLE

⚠️ **Failure to follow the safety guidelines listed may result in voiding any applicable warranty, serious bodily injury, or death.**

⚠️ It is very important that you properly fill out your product registration form at registration.intheditch.com to register your equipment. By submitting the information within 15 days of your purchase, your warranty will be validated, ensuring that your equipment will be protected subject to the terms and conditions set out herein. In the event we need to contact you concerning your registered equipment, Product Updates, Service Bulletins, or Product Recalls, the information you have provided on the product registration form will ensure your immediate notification. Do your part and let us help you by filling out your product registration form.

SAFETY INFORMATION

This manual is supplied with the ITD unit to better familiarize the owner/operator with proper operation and maintenance procedures. The information contained in this manual must be thoroughly understood by all operating and maintenance personnel to ensure the protection of the operator of this unit and to prolong the unit's working life.

SAFETY & PRECAUTIONS

Please note that the X-Series™ Dollies are NOT prime movers. They are designed to transport the disabled vehicle to the nearest safe haven for placement on a vehicle carrier.

Before operating, perform a thorough visual inspection of the unit and accessories. Specific visual inspection recommendations are listed below under X-Series™ Dollies Operations.

Before operating X-Series™ Dollies, refer to the capacity labels on the main tube near the Dolly Handle.

Do not use the X-Series™ Dollies for the movement or transportation of humans or livestock animals.

Do not Mix and Match Axles with previously models.

LOAD RATINGS

 If wheels or tires have been replaced with aftermarket units, load rating may be decreased to that of the lowest rated piece (i.e. wheel or tire).

X-Series™ XL SD Dolly (ITD2778)

Do not exceed loads of 3040 lbs. (1379 kg). It is always dangerous to apply any load which is greater than the rated load shown on the decal. If unsure of the vehicle weight, consult the AAA manual.

X-Series™ XL XD Dolly (ITD2790)

Do not exceed loads of 4000 lbs. (1814 kg). It is always dangerous to apply any load which is greater than the rated load shown on the decal. If unsure of the vehicle weight, consult the AAA manual.

X-Series™ SLX SD Dolly (ITD2878)

Do not exceed loads of 3040 lbs. (1379 kg). It is always dangerous to apply any load which is greater than the rated load shown on the decal. If unsure of the vehicle weight, consult the AAA manual.

X-Series™ SLX XD Dolly (ITD2890)

Do not exceed loads of 4000 lbs. (1814 kg). It is always dangerous to apply any load which is greater than the rated load shown on the decal. If unsure of the vehicle weight, consult the AAA manual.

 **Failure to follow the safety guidelines listed may result in voiding any applicable warranty, serious bodily injury, or death.**

 It is very important that you properly fill out your product registration form at registration.intheditch.com to register your equipment. By submitting the information within 15 days of your purchase, your warranty will be validated, ensuring that your equipment will be protected subject to the terms and conditions set out herein. In the event we need to contact you concerning your registered equipment, Product Updates, Service Bulletins, or Product Recalls, the information you have provided on the product registration form will ensure your immediate notification. Do your part and let us help you by filling out your product registration form.

DOLLY MAINTENANCE

Visual Inspection

 **IT IS THE OPERATOR'S RESPONSIBILITY TO INSPECT DOLLIES BEFORE EACH USE. INSPECTION SHOULD BE A PART OF THE OPERATOR'S DAILY CIRCLE CHECK OF THE VEHICLE.**

Before each use, perform a thorough visual inspection of the unit and all accessories. (Dolly, Straps, Break-over Bar, and Axles)

Inspect for:

- Evidence of physical damage such as cracking
- Bending
- Deformation of plates and welds
- Cracking or flaking of powder coat or paint
- Fraying or deterioration of tie-downs or their mechanical members
- Loose rivets or missing end caps from the Dolly Axles
- Do not Mix and Match Axles with previously models.
- Confirm that the cam locks engage fully
- Confirm that the axle snap button has been fully engaged (See page 23)

Maintenance (Each Use)

Always perform regular maintenance of the X-Series™ Dollies and its parts. Prior to each use:

- Check the tire pressure - assure it is at the recommended pressure listed on the tire side wall.
- Inspect Tie-Downs for frays, kinks, and defects. Replace immediately if any damage exists.
- Inspect the Break-over Bar for deformation. Replace if necessary, with a Break-over Bar from ITD.

Maintenance (3 Months)

- Check Lug Nuts on Dolly Wheels. Tighten to recommended 95ft-lbs torque.
- Check spindle pivot pin, 1/2" SS Thin Nylock Nut. ITD recommends it be tightened to 25ft-lbs torque.
- Inspect wheel bearings:
 - XL Series - Verify spindle nut at recommended 125ft-lbs torque.
 - SLX Series - Fully tighten 1" spindle nut until snug, then loosen 1/8 turn.
 - Verify nut retainer is present and fully installed.
- Under normal use, inspect and repack the wheel bearings once every three months (SLX Dollies only).
- Under severe use, repack the wheel bearings monthly (SLX Dollies only).
- Use wheel bearing grease - ITD recommends Valvoline Optimum Choice wheel bearing grease.
- Check XL Dolly Hubs for loose fitting parts, wear, and audible squeaks. If signs of wear, ITD recommends taking the dolly to a professional mechanic for evaluation of the XL hub and bearing assembly

Aluminum Wheel Care

ITD aluminum wheels are coated with a durable clear coat to allow for a long-lasting finish. To clean, simply use soap and water. **DO NOT** use any abrasive polish or cleaner. Doing so may lead to damage to the wheel.

Tire Inspection

When performing maintenance, check X-Series™ Dolly tires for irregular tread wear on tire tread and sidewalls, cracking, scrapes, bulges, cuts, foreign objects and debris. Remove any foreign objects or debris embedded in the tread to prevent damage. Tires with excessive damage on the tread or sidewall(s) should be removed from service and replaced. Minimum tread depth should be no less than 2/32". Check for proper tire pressure by referencing the PSI located on the tire sidewall. 4.80 X 8 = 90 PSI cold, 5.70 X 8 = 100 PSI cold

If any unusual conditions exist, contact ITD and remove the equipment from service immediately. Repair or replace the necessary components with ITD certified parts. Only use In The Ditch approved replacement parts. Failure to do so could result in damage, injury or death!

 **Failure to follow the safety guidelines listed may result in voiding any applicable warranty, serious bodily injury, or death.**

 It is very important that you properly fill out your product registration form at registration.intheditch.com to register your equipment. By submitting the information within 15 days of your purchase, your warranty will be validated, ensuring that your equipment will be protected subject to the terms and conditions set out herein. In the event we need to contact you concerning your registered equipment, Product Updates, Service Bulletins, or Product Recalls, the information you have provided on the product registration form will ensure your immediate notification. Do your part and let us help you by filling out your product registration form.

Grease Points

Grease Cam Locks in the Dis-Engaged position with 1 to 2 pumps from a grease gun.



Speed® Lube Through Spindle Lubrication System

The SLX™ SD Dolly and SLX™ XD™ Dolly have been designed with low maintenance in mind. The Speed® Lube Through Spindle Lubrication System allows bearing grease to enter the center of the spindle with a grease gun. It forces new bearing grease into the spindle, pushing the old bearing grease forward, then exiting the spindle. This completely repacks the bearing with new, clean bearing grease. Removal of the hub is not needed to perform maintenance. First remove the rubber plug from the spindle dust cap. With a standard grease gun, inject fresh bearing grease into the zerk until old bearing grease is pushed out the exit hole. Rotate the tire to thoroughly lubricate the spindle. Wipe clean to remove old bearing grease.

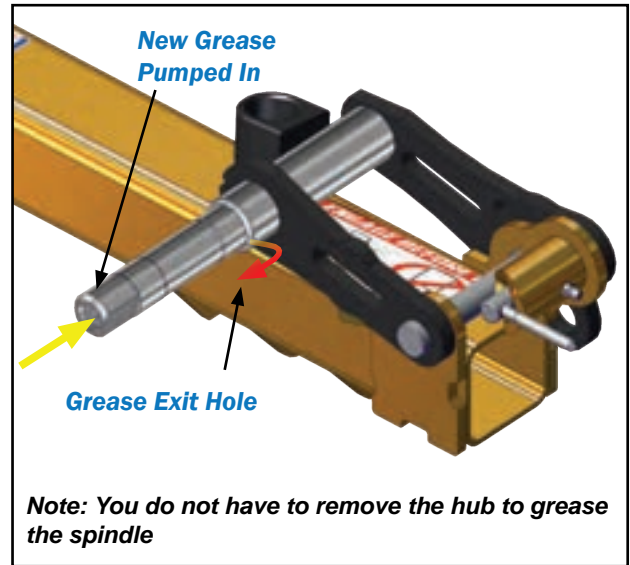

! Make sure that you use **Wheel Bearing Grease** to lubricate the Speed® Lube Through Spindle Lubrication System.

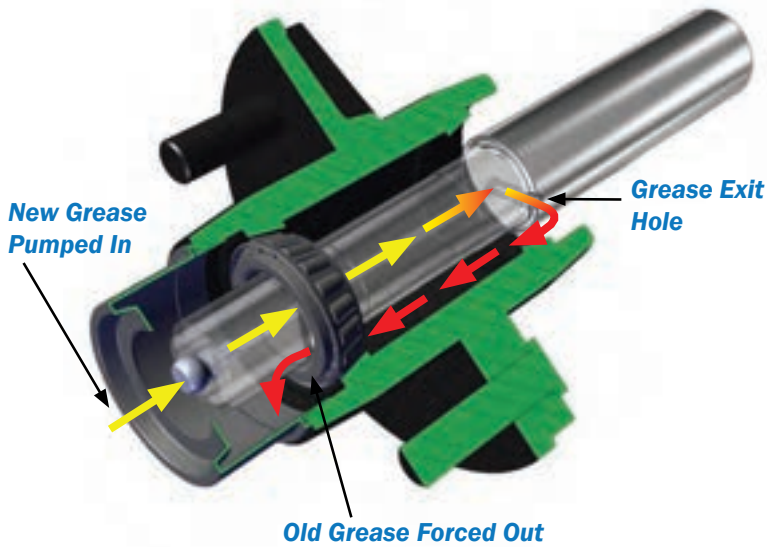

In The Ditch recommends using Valvoline Optimum Choice when lubricating X-Series™ SLX Dolly grease points.

! Failure to follow the safety guidelines listed may result in voiding any applicable warranty, serious bodily injury, or death.

! It is very important that you properly fill out your product registration form at registration.intheditch.com to register your equipment. By submitting the information within 15 days of your purchase, your warranty will be validated, ensuring that your equipment will be protected subject to the terms and conditions set out herein. In the event we need to contact you concerning your registered equipment, Product Updates, Service Bulletins, or Product Recalls, the information you have provided on the product registration form will ensure your immediate notification. Do your part and let us help you by filling out your product registration form.

Installation of Replacement Spindle Assemblies

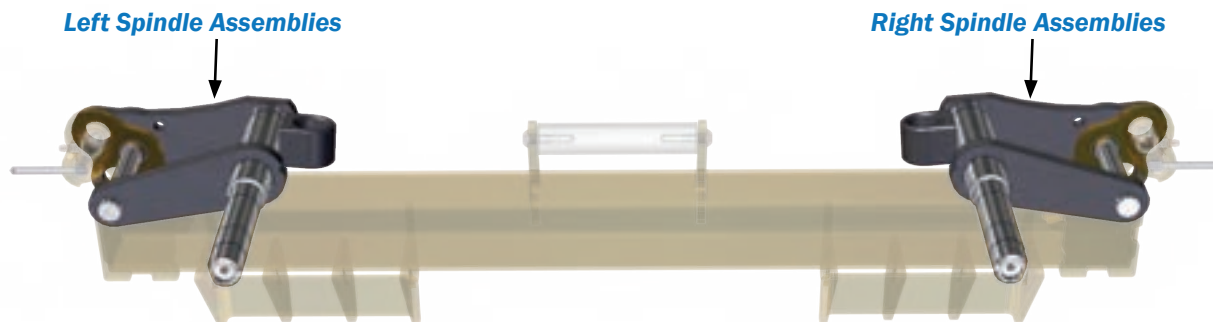

Replacement Bolt-On Spindle Assemblies Include: (1) Spindle Assembly, (1) Notched Spindle Pin, (2) 3/4" Bushings, (1) 1/2" SS Washer, (1) 1/2" Thin Nylock Nut.

Example - SLX SD Replacement Bolt-On Spindle Right (ITD7906-R)



Please refer to pages 6-13 to verify your exact model and part numbers of replacement parts.

 **Failure to follow the safety guidelines listed may result in voiding any applicable warranty, serious bodily injury, or death.**

 It is very important that you properly fill out your product registration form at registration.intheditch.com to register your equipment. By submitting the information within 15 days of your purchase, your warranty will be validated, ensuring that your equipment will be protected subject to the terms and conditions set out herein. In the event we need to contact you concerning your registered equipment, Product Updates, Service Bulletins, or Product Recalls, the information you have provided on the product registration form will ensure your immediate notification. Do your part and let us help you by filling out your product registration form.

Spindle Assembly Removal and Install:

1. Remove 1/2" Thin Nylock Nut and 1/2" SS Washer and Notched Spindle Pin.

See Fig. 1

2. The spindle assembly should lift out of the way.

See Fig. 2

3. Remove the 3/4" Bushings.

See Fig. 3

4. To install replacement Spindle, simply reverse steps 1 to 3. ITD recommends the nut to be tightened to 25 ft-lbs. torque

5. The Notched Spindle Pin can only be installed from one direction to prevent installation error.

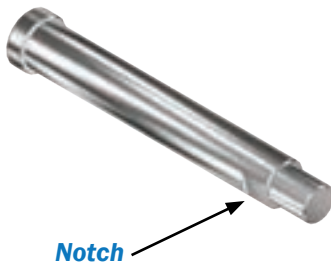

6. The installed Spindle Assembly should rotate freely and the Cam Lock should lock into place. Visually verify that it locks and listen for an audible "CLICK".

See Fig. 4

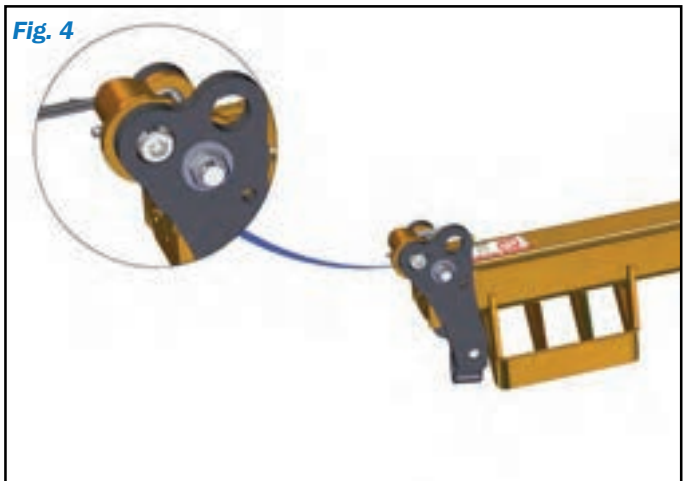
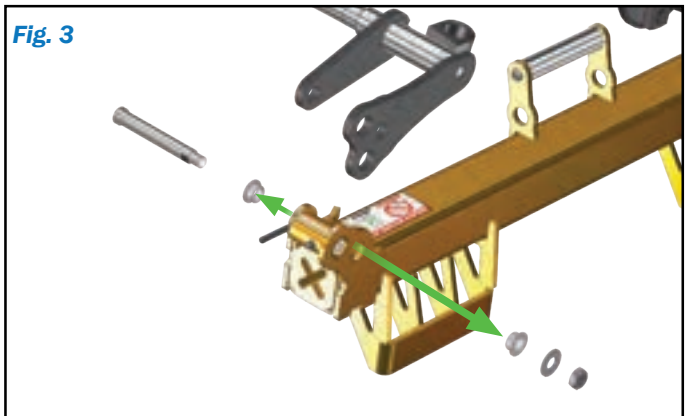
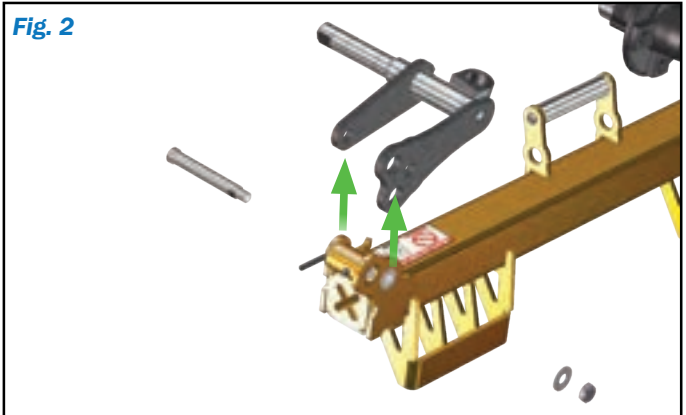
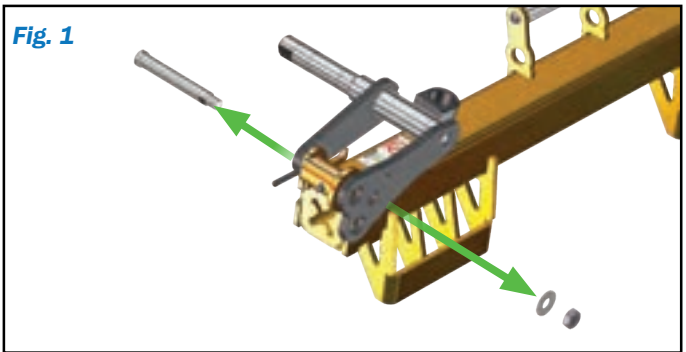

⚠ Failure to follow the safety guidelines listed may result in voiding any applicable warranty, serious bodily injury, or death.

⚠ It is very important that you properly fill out your product registration form at registration.intheditch.com to register your equipment. By submitting the information within 15 days of your purchase, your warranty will be validated, ensuring that your equipment will be protected subject to the terms and conditions set out herein. In the event we need to contact you concerning your registered equipment, Product Updates, Service Bulletins, or Product Recalls, the information you have provided on the product registration form will ensure your immediate notification. Do your part and let us help you by filling out your product registration form.

DOLLY OPERATIONS

⚠️ *ITD Brand Dollies, Axles, Mounts, and related products are intended to be used solely by towing operators who have the requisite training and experience. If you do not have the requisite experience and training as a towing operator DO NOT USE these products.*

There is no substitution for hands on training. ITD recommends taking a training course from AAA, C.T.T.A., WreckMaster or CAA. Go to INTHEDITCH.com and YouTube to watch all the most up to date instructional videos.

▶ VIDEO ONLINE
www.intheditch.com

Loading:



1 Adjust Dolly Axles

Extend axles to the minimum length required to span the width of the vehicle, ensuring the thumb button re-engages at the extended setting.

2 Proper Axle Adjustment:

When you are extending the length of the dolly Axles, it is very important that you extend them **NO MORE THAN 4"** past the side wall of the vehicle tire.



⚠️ *Over extending your axle results in increased stress on axle and dolly, which could result in personal injury!*

⚠️ *Failure to follow the safety guidelines listed may result in voiding any applicable warranty, serious bodily injury, or death.*

⚠️ It is very important that you properly fill out your product registration form at registration.intheditch.com to register your equipment. By submitting the information within 15 days of your purchase, your warranty will be validated, ensuring that your equipment will be protected subject to the terms and conditions set out herein. In the event we need to contact you concerning your registered equipment, Product Updates, Service Bulletins, or Product Recalls, the information you have provided on the product registration form will ensure your immediate notification. Do your part and let us help you by filling out your product registration form.

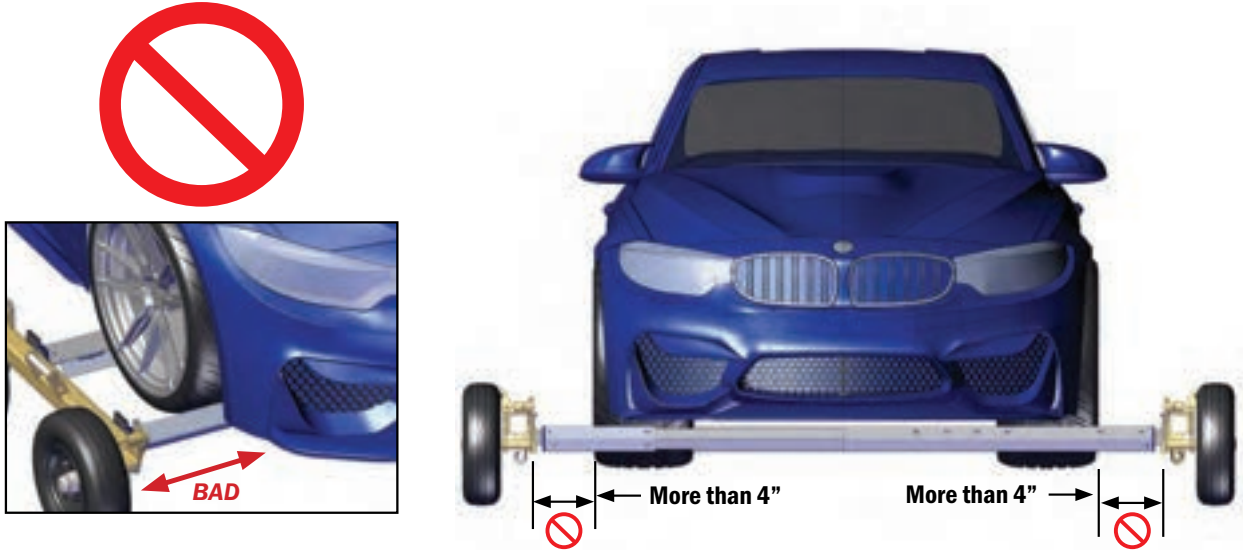

3 Prepare Dolly Axles and Side Frames

Place the dolly axles and side frames on the ground, in the configuration shown below. With dollies centered and parallel to vehicle tires.

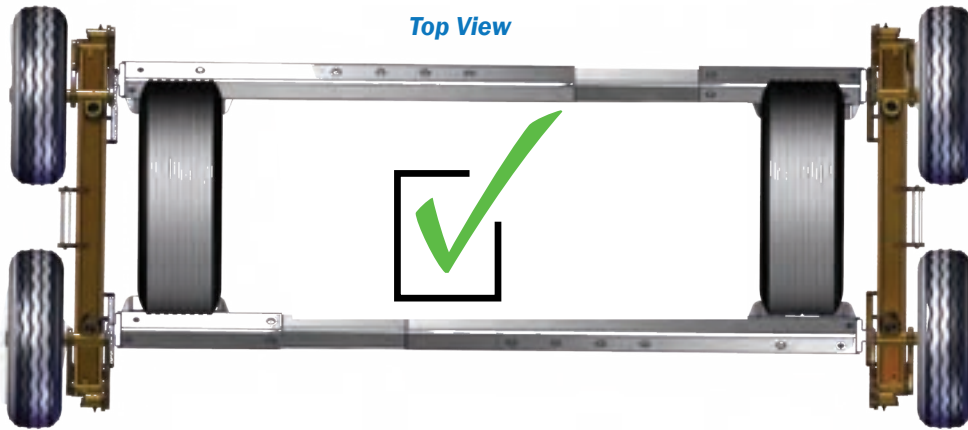

WARNING:
SNAP BUTTON MUST BE FULLY ENGAGED
BEFORE USE OR TRANSPORT

**FAILURE TO ENGAGE SNAP BUTTON MAY
RESULT IN PERSONAL INJURY**



⚠ Failure to follow the safety guidelines listed may result in voiding any applicable warranty, serious bodily injury, or death.

⚠ It is very important that you properly fill out your product registration form at registration.intheditch.com to register your equipment. By submitting the information within 15 days of your purchase, your warranty will be validated, ensuring that your equipment will be protected subject to the terms and conditions set out herein. In the event we need to contact you concerning your registered equipment, Product Updates, Service Bulletins, or Product Recalls, the information you have provided on the product registration form will ensure your immediate notification. Do your part and let us help you by filling out your product registration form.

4 Positioning Dolly Side Frames

- Rotate Cam locks to release tires from storage position.
- Allow wheel pivot arms to rotate until the tires hit the ground.
- Position the dolly side frames while the Cam-Locks stay in detents.



5 Connect Dolly Axles to Dollies

Place the Engagement Tabs into Axle Cradles of both dollies.

Note: Assure both dollies use identical cradle positions, such that dolly axles are parallel to each other and perpendicular to side frames.

 VIDEO ONLINE
www.intheditch.com

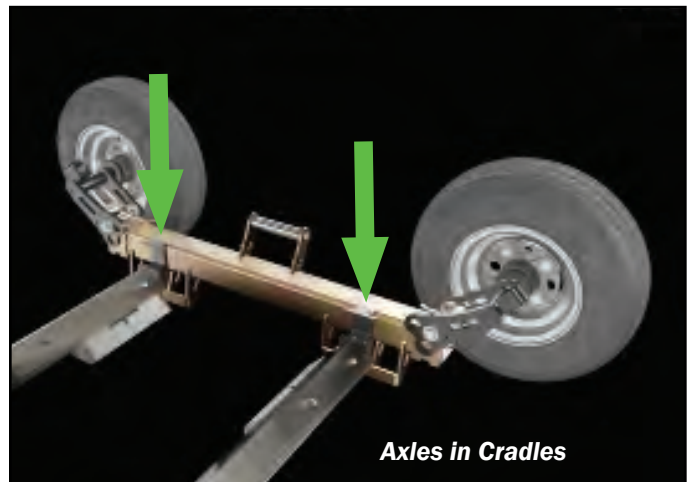

6 Insert Break-over Bar & make sure Vehicle is in Neutral.

Make sure to shift the vehicle you are about to dolly into neutral. Then, insert the break-over bar into the dolly's receiver tube.

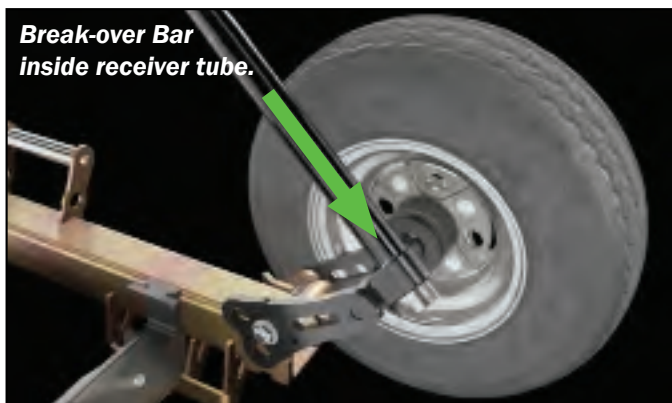

7 Pre-Engage Cam-lock

Rotate the Cam-lock back towards the engaged position to ready it. Once the hole on the spindle reaches the right spot, the Cam-lock will automatically engage.

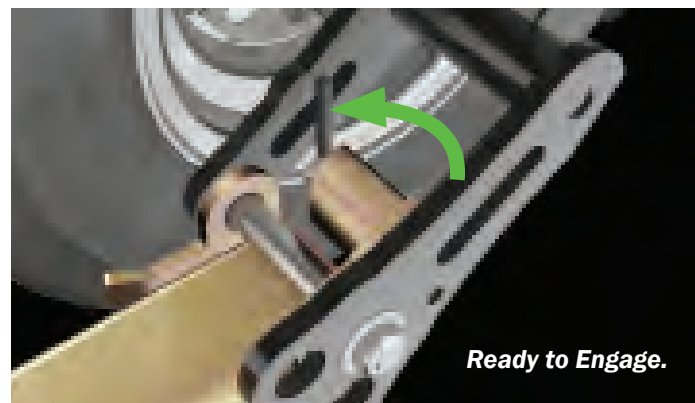

⚠️ Failure to follow the safety guidelines listed may result in voiding any applicable warranty, serious bodily injury, or death.

⚠️ It is very important that you properly fill out your product registration form at registration.intheditch.com to register your equipment. By submitting the information within 15 days of your purchase, your warranty will be validated, ensuring that your equipment will be protected subject to the terms and conditions set out herein. In the event we need to contact you concerning your registered equipment, Product Updates, Service Bulletins, or Product Recalls, the information you have provided on the product registration form will ensure your immediate notification. Do your part and let us help you by filling out your product registration form.

8 Swing Break-over Bar to Raise Dolly

Grasp the far end of the Break-over Bar with both hands and swing the bar in an arc to raise the dolly assembly.

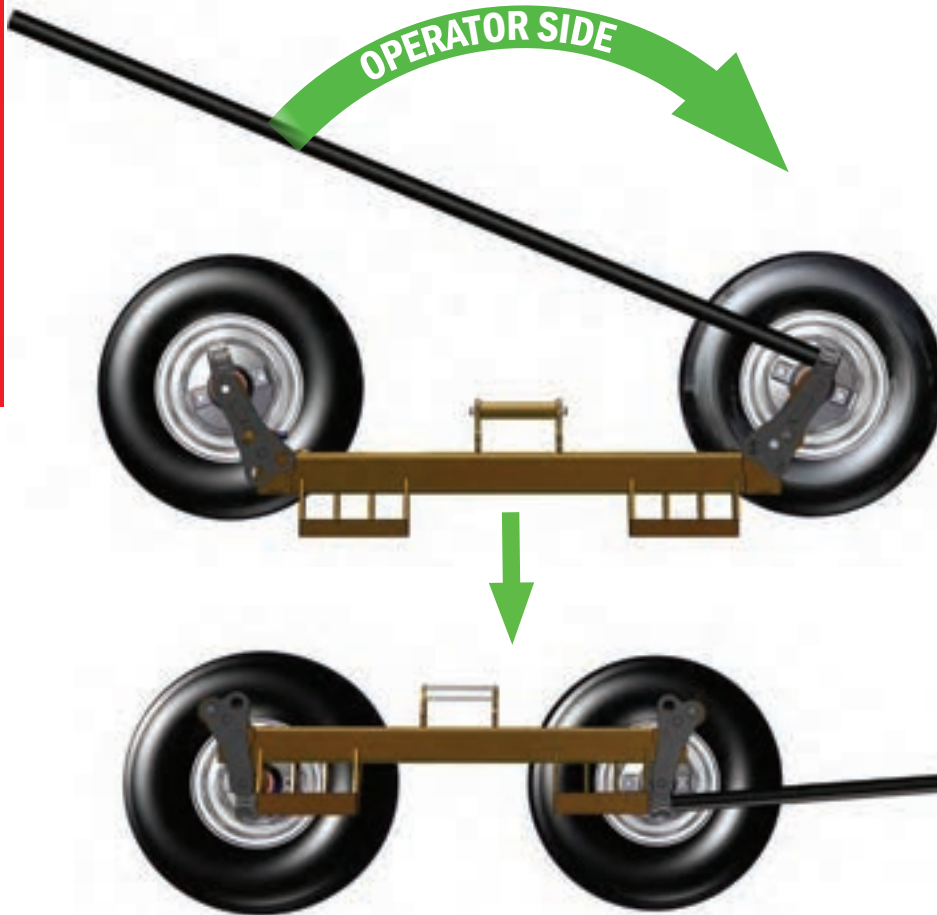

Use both hands while lifting or lowering with break-over bar at all times!

 VIDEO ONLINE
www.intheditch.com

NOTE: If you have pre-engaged the Cam-lock, you should hear an audible “click” when the Cam-lock locks into the spindle, keeping the wheel in place.

 ALWAYS KEEP BOTH HANDS ON THE BREAK-OVER BAR WHILE RAISING THE DOLLY! ALWAYS STAY ON OPERATOR SIDE OF BREAK-OVER BAR!

EXTRA CAUTION SHOULD BE USED IF LOADING OR UNLOADING ON UNEVEN PAVEMENT, LOOSE GRAVEL, SNOW, WATER, OR ICE!

THE SAME OPERATOR MUST LOAD AND UNLOAD THE DOLLY. CHANGES IN OPERATORS WILL RESULT IN UNFAMILIAR LOADS, WHICH MAY RESULT IN SERIOUS INJURY!

IF BREAKER BAR IS GOING TO COLLIDE WITH THE CAR, IT MAY SUGGEST YOUR DOLLY OR AXLES AREN'T INSTALLED PROPERLY!

 **Failure to follow the safety guidelines listed may result in voiding any applicable warranty, serious bodily injury, or death.**

 It is very important that you properly fill out your product registration form at registration.intheditch.com to register your equipment. By submitting the information within 15 days of your purchase, your warranty will be validated, ensuring that your equipment will be protected subject to the terms and conditions set out herein. In the event we need to contact you concerning your registered equipment, Product Updates, Service Bulletins, or Product Recalls, the information you have provided on the product registration form will ensure your immediate notification. Do your part and let us help you by filling out your product registration form.

9 Assure Cam-lock Engagement

With the assembly fully raised, the Cam-Lock mechanism will visually re-engage by snapping into the closed position.

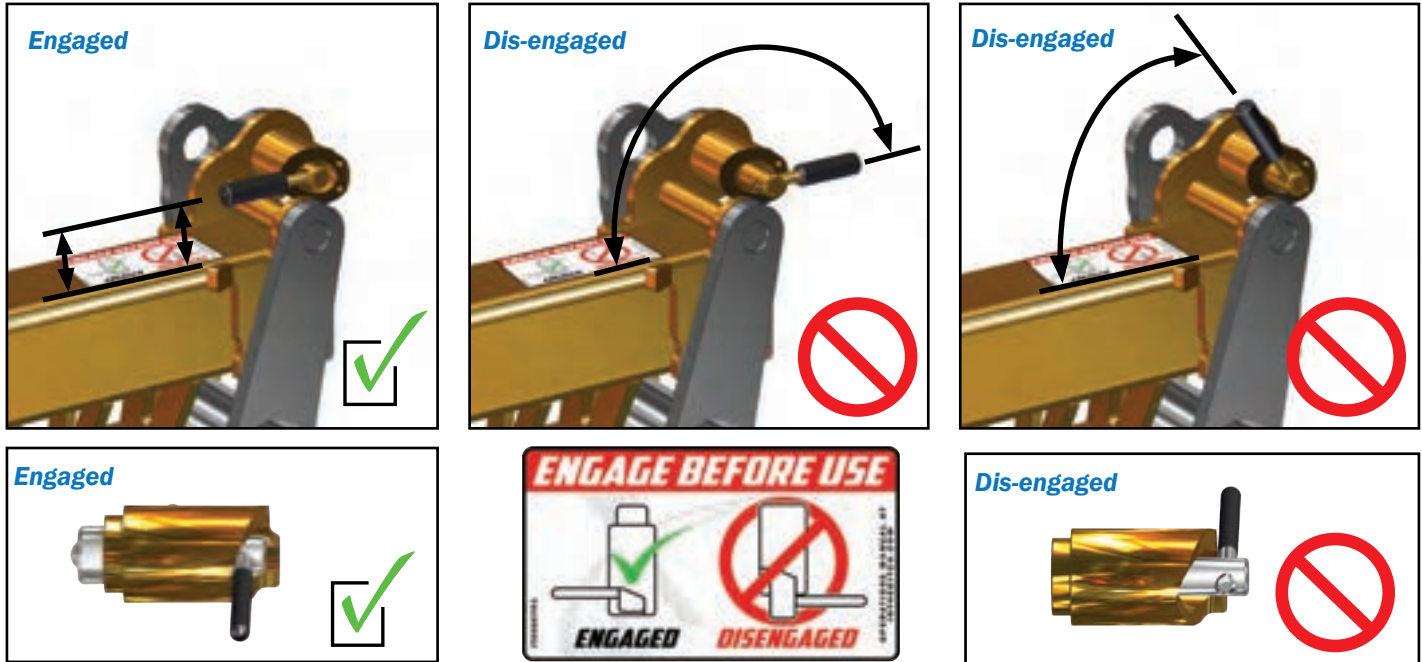

Note: An engaged Cam-Lock can be distinguished by the roll pin lying flat against the body in a position parallel to the dolly tube. If not visually engaged, lower the dolly into the starting position before inspecting the Cam-Lock.

10 Raise Remaining Tires on Dolly

Follow steps 6 through 9 to raise the additional 3 (three) tires of the dolly.

11 Secure Ratchet Straps

Verify that the vehicle is in neutral and the brake is released so the tire can rotate. Pass the ratchet straps behind the vehicle tire, attaching the hooked ends to the mounts on the dolly handle. Ratchet the straps to secure the dolly to the towed vehicle.

Verify that the Ratchet strap has two full wraps on the ratchet drum before you tighten them down.

Note: The towed vehicle must be in neutral and the emergency brake released.



SECUREMENT It is the driver / operator's responsibility to ensure that nothing can come loose from any part of the truck or transport vehicle, or the vehicle being towed. It is the operator's responsibility to make sure that all items are in good working order and are properly secured!

Failure to follow the safety guidelines listed may result in voiding any applicable warranty, serious bodily injury, or death.

It is very important that you properly fill out your product registration form at registration.intheditch.com to register your equipment. By submitting the information within 15 days of your purchase, your warranty will be validated, ensuring that your equipment will be protected subject to the terms and conditions set out herein. In the event we need to contact you concerning your registered equipment, Product Updates, Service Bulletins, or Product Recalls, the information you have provided on the product registration form will ensure your immediate notification. Do your part and let us help you by filling out your product registration form.

⚠ Follow all local and state laws concerning proper towing: We recommend you consult www.wreckmaster.com or your state association for additional training.

Transporting

⚠ WHILE TOWING A VEHICLE ON DOLLIES, DO NOT EXCEED 50 MPH!

- ITD dollies are designed for on-road use only, and are not approved for freeway driving.
- Potholes should be approached at a low rate of speed.
- ITD recommends while towing with dollies to place the casualty in neutral to allow tire to move with the dolly.

Unloading

1 Remove Ratchet Straps

With the vehicle secured in the wheel lift of the tow truck remove ratchet straps on dolly.

⚠ THE SAME OPERATOR MUST LOAD & UNLOAD THE DOLLY. CHANGES IN OPERATORS WILL RESULT IN UNFAMILIAR LOADS, WHICH MAY RESULT IN SERIOUS INJURY

2 Disengage Cam-lock

Rotate the handle of the cam-lock to disengage.

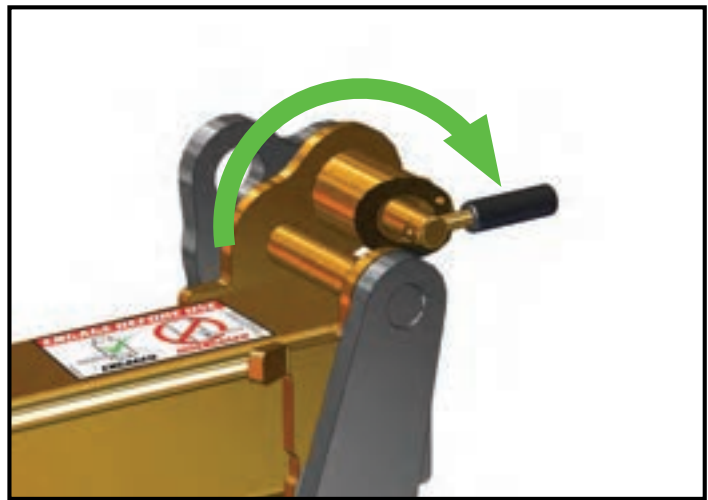

⚠ Failure to follow the safety guidelines listed may result in voiding any applicable warranty, serious bodily injury, or death.

⚠ It is very important that you properly fill out your product registration form at registration.intheditch.com to register your equipment. By submitting the information within 15 days of your purchase, your warranty will be validated, ensuring that your equipment will be protected subject to the terms and conditions set out herein. In the event we need to contact you concerning your registered equipment, Product Updates, Service Bulletins, or Product Recalls, the information you have provided on the product registration form will ensure your immediate notification. Do your part and let us help you by filling out your product registration form.

3 Insert Break-Over Bar

Keeping both hands on the break-over bar, insert into the receiver tube on the dolly. Stay on operator side while lowering.

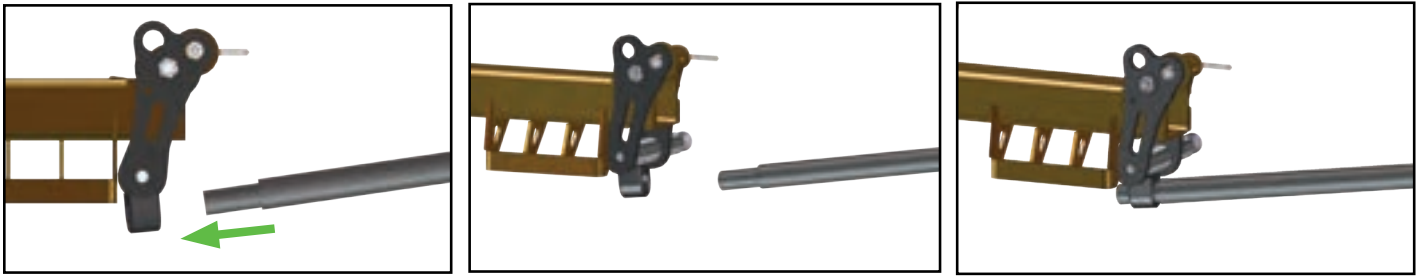
**4 Gently move spindle assembly to Lower the Dolly**

With two hands on the Break-Over Bar, walk the Break-over Bar in an arc to gently lower one end of the dolly side frame.

 **Use extreme caution and stay on the operator side of the Break-Over Bar! Always keep both hands on the Break-Over Bar while lowering the dolly!**

5 Lower the Remaining Dolly Sides.

Repeat steps two (2) through four (4) to fully lower both dollies.

6 Remove and Collapse Dolly Axles.

Confirm that Axle Snap button has been fully engaged in the axle collapsed position.

7 Re-engage Dolly Cam-locks.

Rotate the tires upward on the dollies. Re-engage the Cam-Locks to secure the tires and ease transportation of the dollies.

 **Failure to follow the safety guidelines listed may result in voiding any applicable warranty, serious bodily injury, or death.**

 It is very important that you properly fill out your product registration form at registration.intheditch.com to register your equipment. By submitting the information within 15 days of your purchase, your warranty will be validated, ensuring that your equipment will be protected subject to the terms and conditions set out herein. In the event we need to contact you concerning your registered equipment, Product Updates, Service Bulletins, or Product Recalls, the information you have provided on the product registration form will ensure your immediate notification. Do your part and let us help you by filling out your product registration form.

Tips & Tricks

The Crunch Zone

A simple little tip when you find yourself in the crunch zone. The crunch zone is anytime you are up against an obstacle such that you cannot fully raise the dolly using the break-over bar.

The following are the steps to get out of the “Crunch Zone” using ITD Dollies

1. Fully load the dolly tire that has full access for the break-over bar.
2. Insert the break-over bar into the BACK SIDE of the receiver tube.
3. Re-engage the Cam-lock and pull the bar towards the frame to lock it into the stowed position. This will raise the vehicle's tire up just enough such that you can pull away from the wall.
4. Repeat steps 1 through 3 on other side of dolly.
5. Once away from the obstacle, re-install the break-over bar in the stowed wheel receiver.
6. Apply a small amount of pressure forward to allow disengage of cam-lock.
7. Load dolly as normal and attach tie downs.

Steps 1-3

Load Dolly Tire you have access to

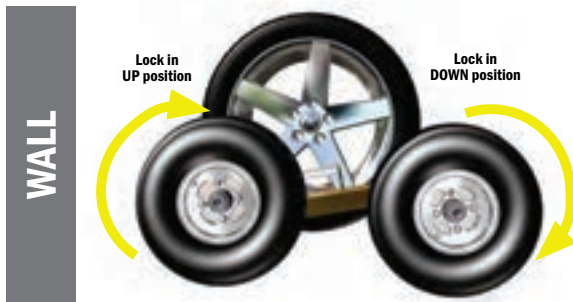

Steps 5

Move vehicle away from obstacle



Steps 6-7

Load vehicle completely



Steps 7

Secure with tie downs



VIDEO ONLINE
www.intheditch.com

WATCH THE INSTRUCTIONAL VIDEOS AT:

www.intheditch.com

Failure to follow the safety guidelines listed may result in voiding any applicable warranty, serious bodily injury, or death.

It is very important that you properly fill out your product registration form at registration.intheditch.com to register your equipment. By submitting the information within 15 days of your purchase, your warranty will be validated, ensuring that your equipment will be protected subject to the terms and conditions set out herein. In the event we need to contact you concerning your registered equipment, Product Updates, Service Bulletins, or Product Recalls, the information you have provided on the product registration form will ensure your immediate notification. Do your part and let us help you by filling out your product registration form.

Walking the Dolly

With the ability to lock the dolly wheels in the stowed position, the ITD dollies have the unique feature of “walking” using the break-over bar. The advantage of walking the dolly is to reduce weight and back strain.

To “Walk the Dolly”:

1. Set the dollies on the ground
2. Insert the break-over bar
3. Walk them back to the towed vehicle.



Quick Extend Axles

ITD aluminum telescoping axles have been designed with large corner radiuses and a domed snap button to allow for a quick extension of the axles.

Quick Extend:

1. Depressing the snap button
2. Place a foot on the axle cap to keep the axle steady
3. Rotate axle pieces
4. Extend swiftly
5. Confirm that Axle Snap button has been fully engaged

With a little practice, extending axles to the correct hole can be quick and easy.

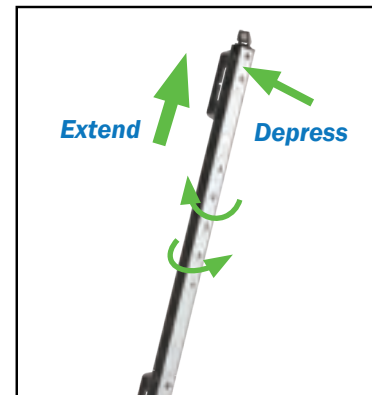

Reducing Lifting Load

When loading or unloading a vehicle in excess of 3000lbs (XD model only), it is helpful to place a piece of lumber under the vehicle tire. This reduces the load felt by the operator when operating the dolly.



 **Before inspecting, operating, or performing maintenance on this product, read the manual thoroughly and fully understand the contents. Keep this manual in a safe, designated place for future reference!**

 **Failure to follow the safety guidelines listed may result in voiding any applicable warranty, serious bodily injury, or death.**

 It is very important that you properly fill out your product registration form at registration.intheditch.com to register your equipment. By submitting the information within 15 days of your purchase, your warranty will be validated, ensuring that your equipment will be protected subject to the terms and conditions set out herein. In the event we need to contact you concerning your registered equipment, Product Updates, Service Bulletins, or Product Recalls, the information you have provided on the product registration form will ensure your immediate notification. Do your part and let us help you by filling out your product registration form.

⚠ Due to variances in manufacturers' wrecker bodies, truck bodies and mounting surfaces, ITD cannot provide explicit mounting requirements for every mounting option. These instructions are to serve only as a guideline. Final installation requirements are left to the discretion of a qualified installer.

⚠ Always mount at a flat, level surface. Do not mount at an angle!

⚠ ITD Brand Dollies, Axles, Mounts, and related products are intended to be used solely by towing operators who have the requisite training and experience. If you do not have the requisite experience and training as a towing operator **DO NOT USE** these products.

⚠ SECUREMENT It is the driver / operator's responsibility to ensure that nothing can come loose from any part of the truck or transport vehicle, or the vehicle being towed. It is the operator's responsibility to make sure that all items are in good working order and are properly secured!

⚠ MODIFICATION **DO NOT** modify or tamper with any ITD product. Doing so will void any applicable warranty and may result in serious injury or death. • Warranties will be voided if any ITD Product is modified or tampered with!

⚠ INSPECTION ITD requires that each operator of a truck or transport vehicle perform a detailed circle check before and after each use of the truck or transport vehicle. This inspection must include the power unit, the towing unit, and all items installed on the unit.

- Do not take chances with your life or other people's lives. Make sure all items are secured and in safe working order.
- Always inspect products for any signs of paint cracking, metal fatigue or premature wear.
- Maintain a visual inspection along with grabbing the products and wiggling or pulling on it to make sure there is no way anything can become dislodged from its mount.
- Remove from service immediately if repairs are needed. Do not take chances.

⚠ MIXING & MATCHING PRODUCTS

- Only use In The Ditch brand mounts with In The Ditch brand products.
- Only use In The Ditch brand replacement parts for In The Ditch brand products.
- **DON'T MIX AND MATCH AXLE MODELS!**
Axle models are not interchangeable.

⚠ • ALWAYS FOLLOW STATE & LOCAL GUIDELINES!

⚠ Failure to follow the safety guidelines listed may result in voiding any applicable warranty, serious bodily injury, or death.

⚠ It is very important that you properly fill out your product registration form at registration.intheditch.com to register your equipment. By submitting the information within 15 days of your purchase, your warranty will be validated, ensuring that your equipment will be protected subject to the terms and conditions set out herein. In the event we need to contact you concerning your registered equipment, Product Updates, Service Bulletins, or Product Recalls, the information you have provided on the product registration form will ensure your immediate notification. Do your part and let us help you by filling out your product registration form.

Go to REGISTRATION.INTHEDITCH.COM for product registration ITS AS EASY AS THESE 4 STEPS!

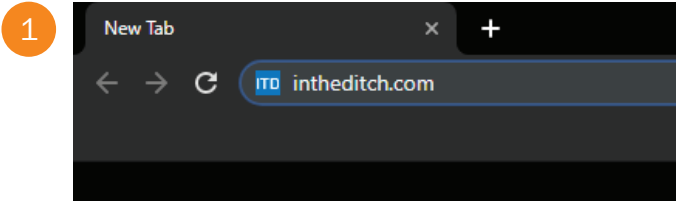

In your browser, navigate to intheditch.com



After navigating to intheditch.com, hover over the extras tab to view an expanded list of links.

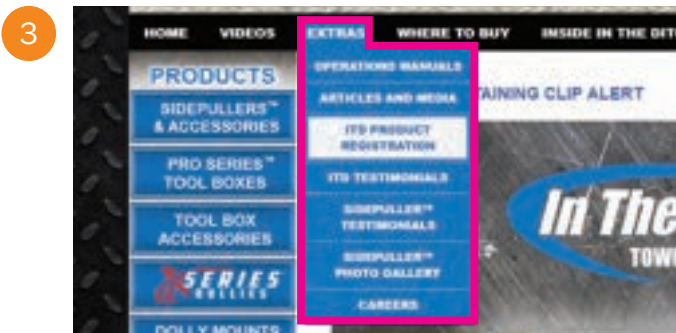

Under the Extras tab, click on "ITD Product Registration".



Complete the form located on the product registration page.

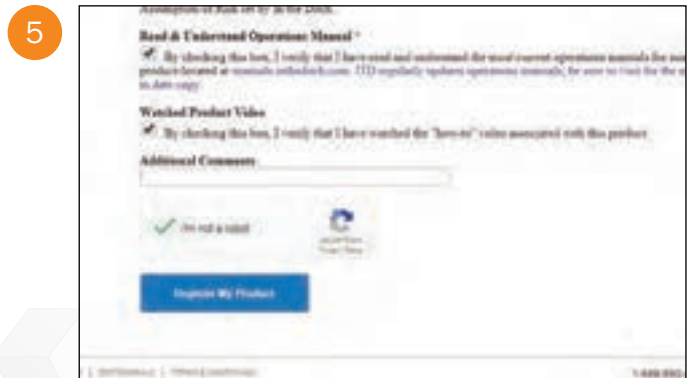

After completing the form, make sure you complete the captcha at the bottom, and click on the "Register My Product" button.

It is very important that you properly fill out your product registration form at registration.intheditch.com (follow the screenshots above) to register your equipment. By submitting the information within 15 days of your purchase, your warranty will be validated, ensuring that your equipment will be protected subject to the terms and conditions set out herein. In the event we need to contact you concerning your registered equipment, Product Updates, Service Bulletins, or Product Recalls, the information you have provided on the product registration form will ensure your immediate notification. Do your part and let us help you by filling out your product registration form. Please fill out the product registration form at registration.intheditch.com within 15 days after purchase. This validates the warranty transfer and is essential for your protection. If ITD should ever need to contact you concerning compliance of your ITD equipment with any applicable safety standards, the information you have provided on the product registration form will ensure your immediate notification.

In the event you were not the original purchaser of the product, we still need you to register your In The Ditch Products.

PLEASE TAKE THE TIME TO FILL OUT THE PRODUCT WARRANTY FORM.

GO TO: REGISTRATION.INTHEDITCH.COM

IF YOU HAVE ANY QUESTIONS PLEASE CALL IN THE DITCH: 1-208-587-7960

**VISIT OUR WEBSITE!
IN THE DITCH.COM**



**PHONE: 1-208-587-7960
EMAIL: sales@intheditch.com**

